



محاسبه نیروها در ماشینکاری

ارایه دهنده:

دکتر پیمان مصدق

دانشیار دانشکده مهندسی مکانیک

دانشگاه صنعتی اصفهان

www.mosadegh.iut.ac.ir

mosadegh@cc.iut.ac.ir



Mental Map

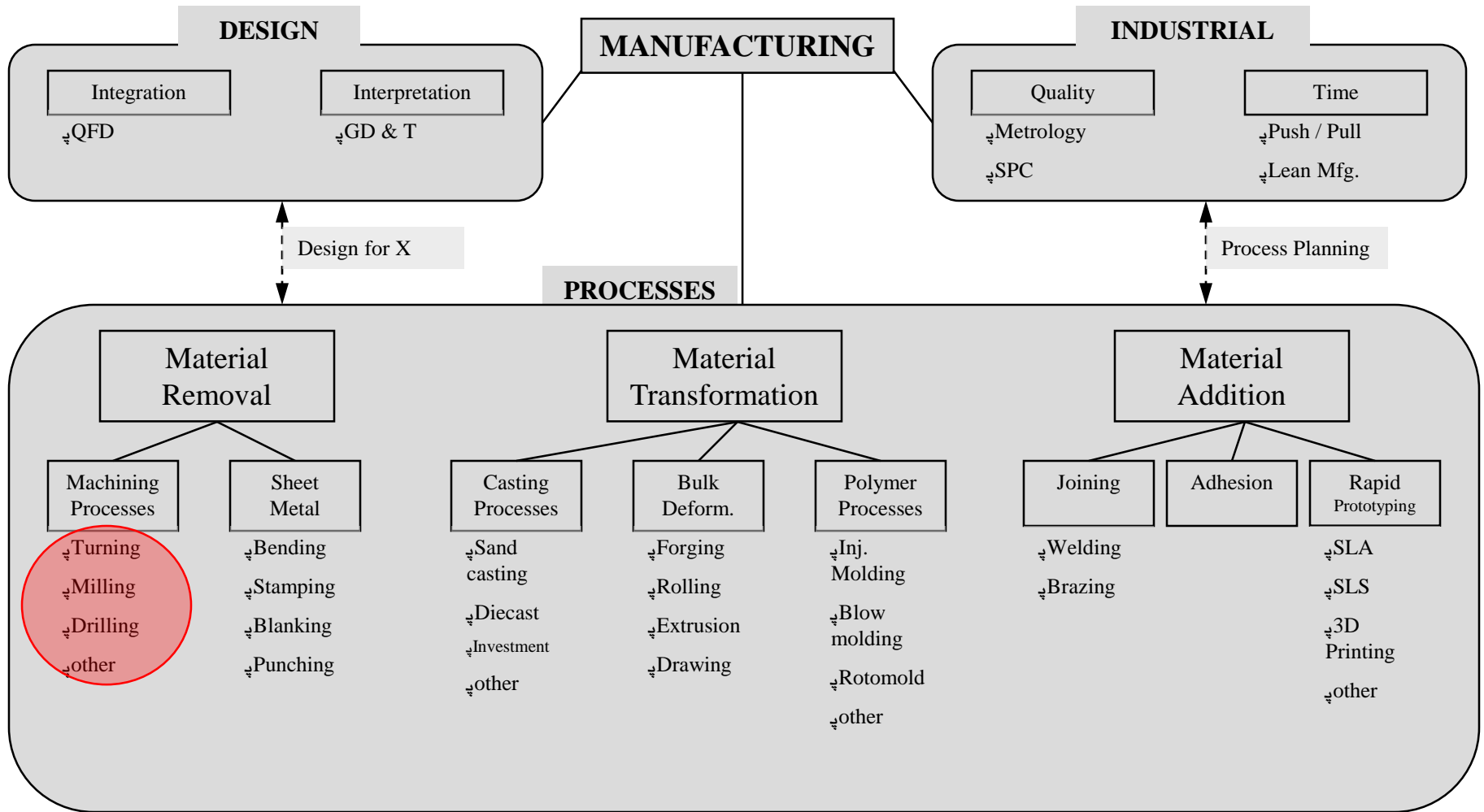



Dependencies

- ❖ Independent variables (fixed by Process Engineer)
 - Tool material and geometry
 - Workpiece material and geometry
 - Cutting feed and speed, depth of cut (Process Parameters)
 - Coolant properties and effects
 - Machine tool structure: close loop or open loop (e.g., stiffness, damping, fixturing)
- ❖ Dependent Variables
 - Chip type (continuous, serrated, discrete)
 - Forces, energy and power required
 - Temperature profile
 - Tool wear and surface finish
 - Tool life



How to Select the Process Parameters?

- ❖ Minimum Cost per part
- ❖ Minimum Time per part (Max. Material Removal Rate)

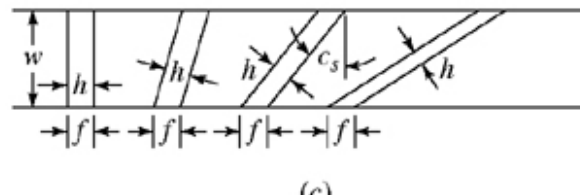
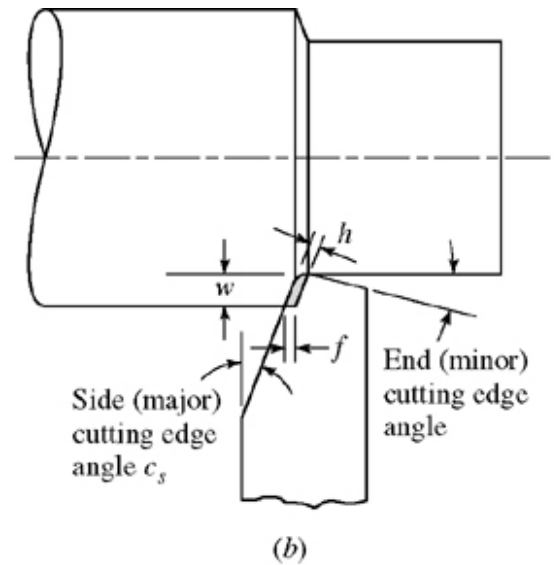
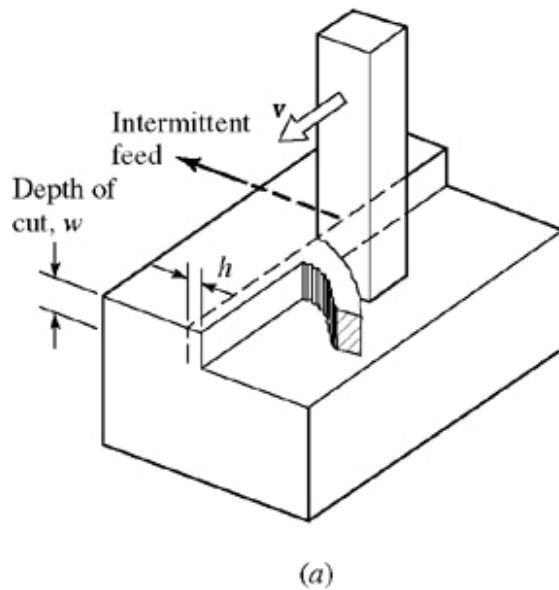

- ❖ Speed (v)
- ❖ Feed (f)
- ❖ Depth of Cut (d)

$$\begin{aligned} \text{MRR} &= f \times d \times v \\ &= w \times h \times v \end{aligned}$$



Oblique Cutting versus Orthogonal Cutting

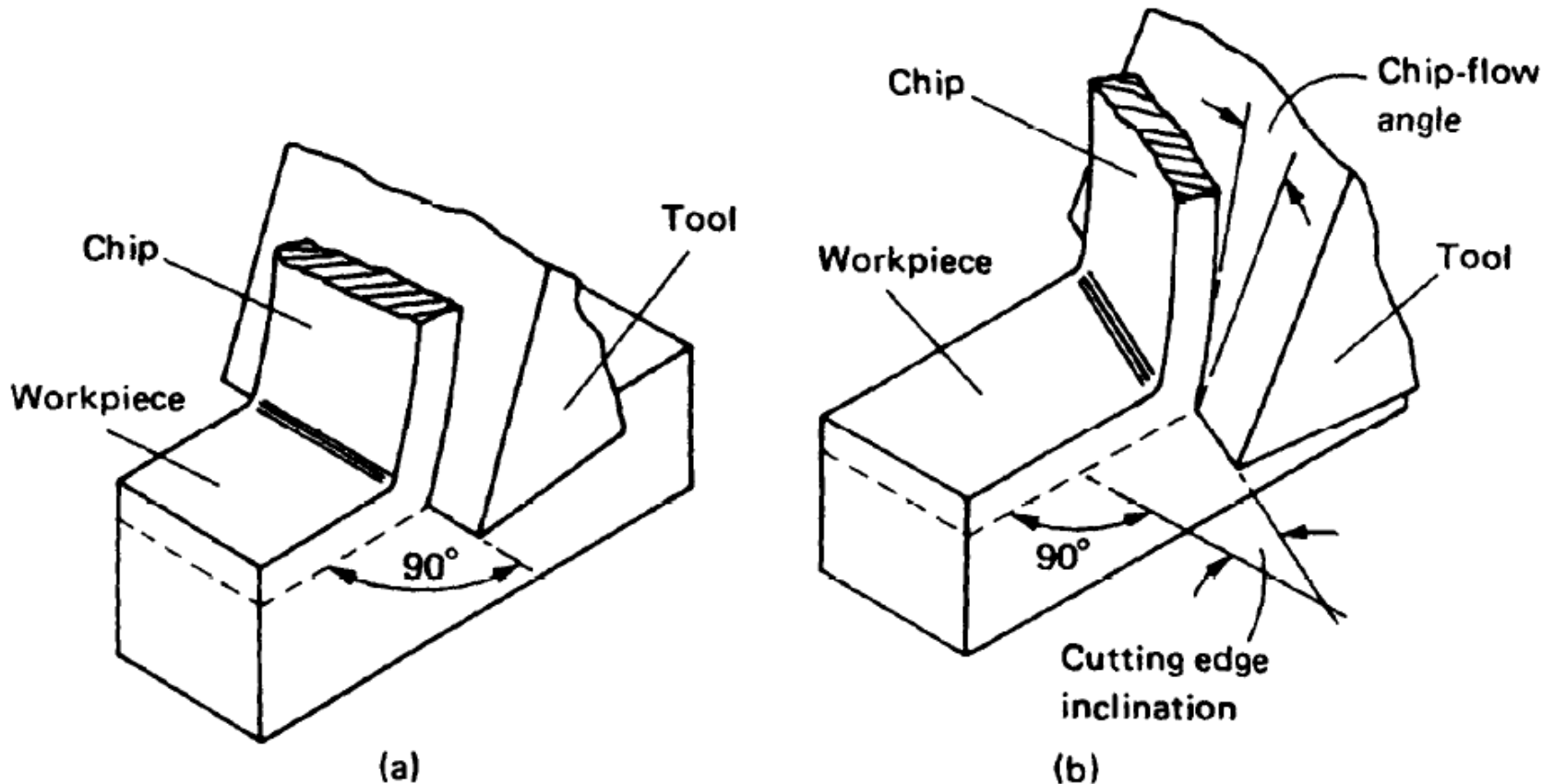

Ideal Orthogonal Cutting is when the cutting edge of the tool is straight and perpendicular to the direction of motion



Chip Formation in Oblique Cutting

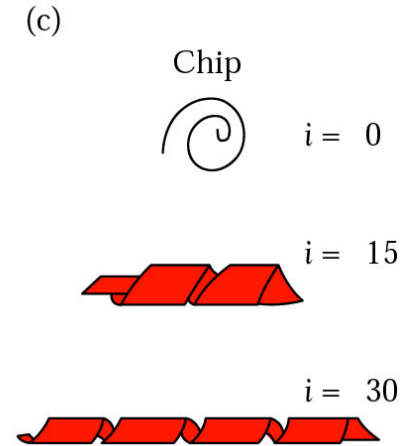
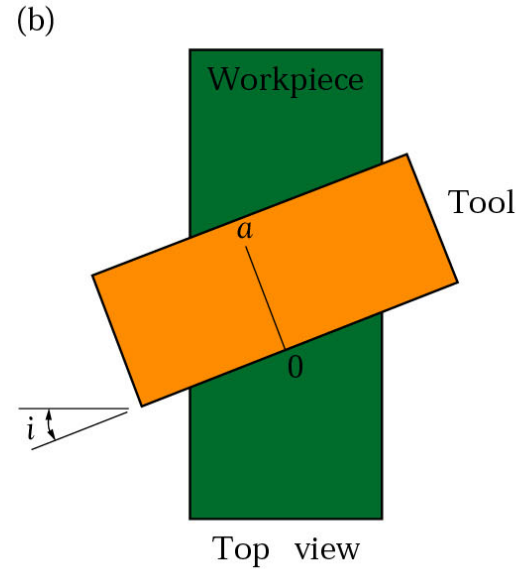
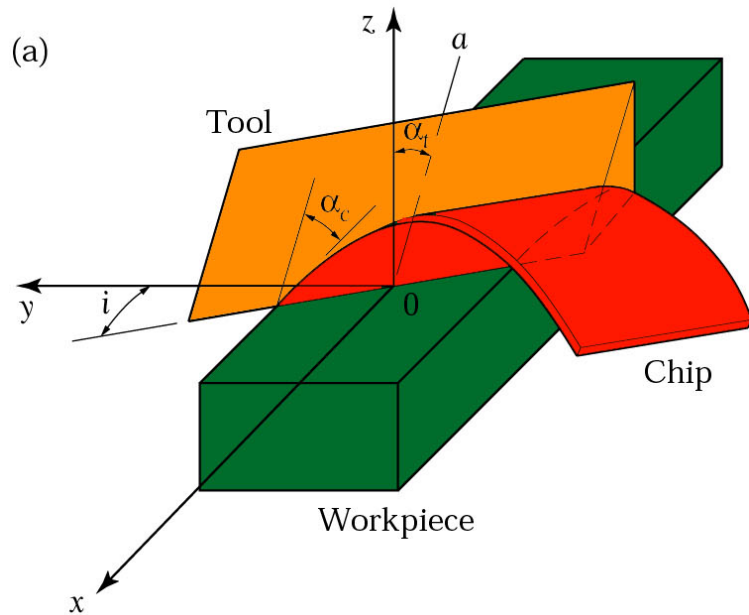

- Tool edge is set at an angle of inclination, i .
- Effective rake angle is larger than normal rake angle, thus cutting force is lower.
- Chip curls into a helical rather than a spiral, easily removed.



Mechanics of Machining

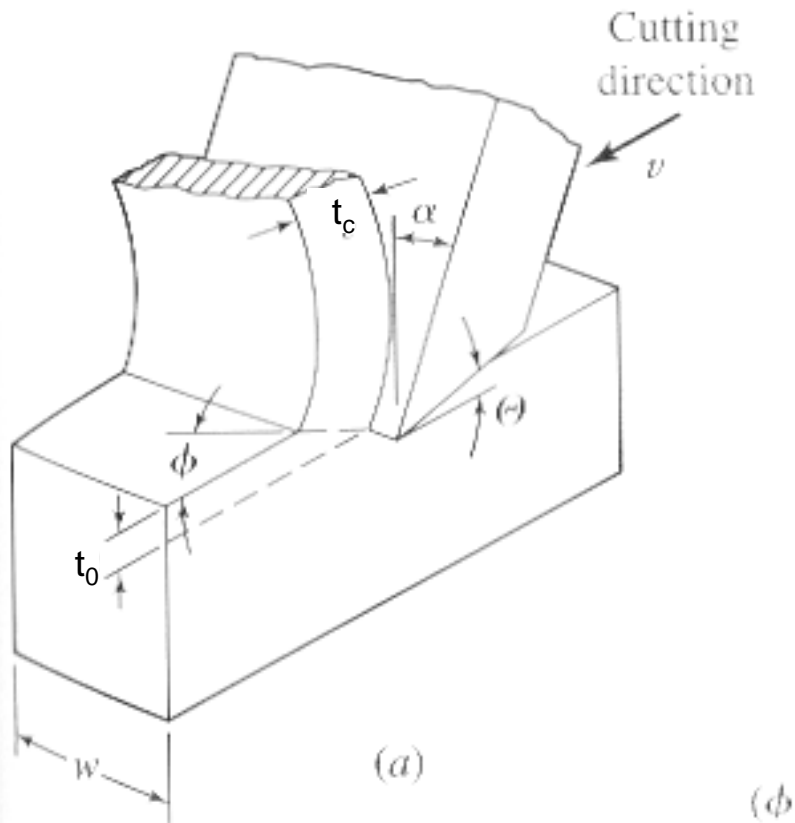

- ❖ Ideal Orthogonal Cutting is when the cutting edge of the tool is straight and perpendicular to the direction of motion.
- ❖ Terminology
 - Rake angle
 - Clearance angle (Relief angle)
 - Cutting speed
 - Undeformed chip thickness
 - Shear plane
 - Shear angle
 - Chip thickness
 - Cutting ratio ($t_0/t_c < 1$)
 - Chip compression ratio ($t_c/t_0 > 1$)



Orthogonal Cutting Model

❖ Idealized Chip Formation

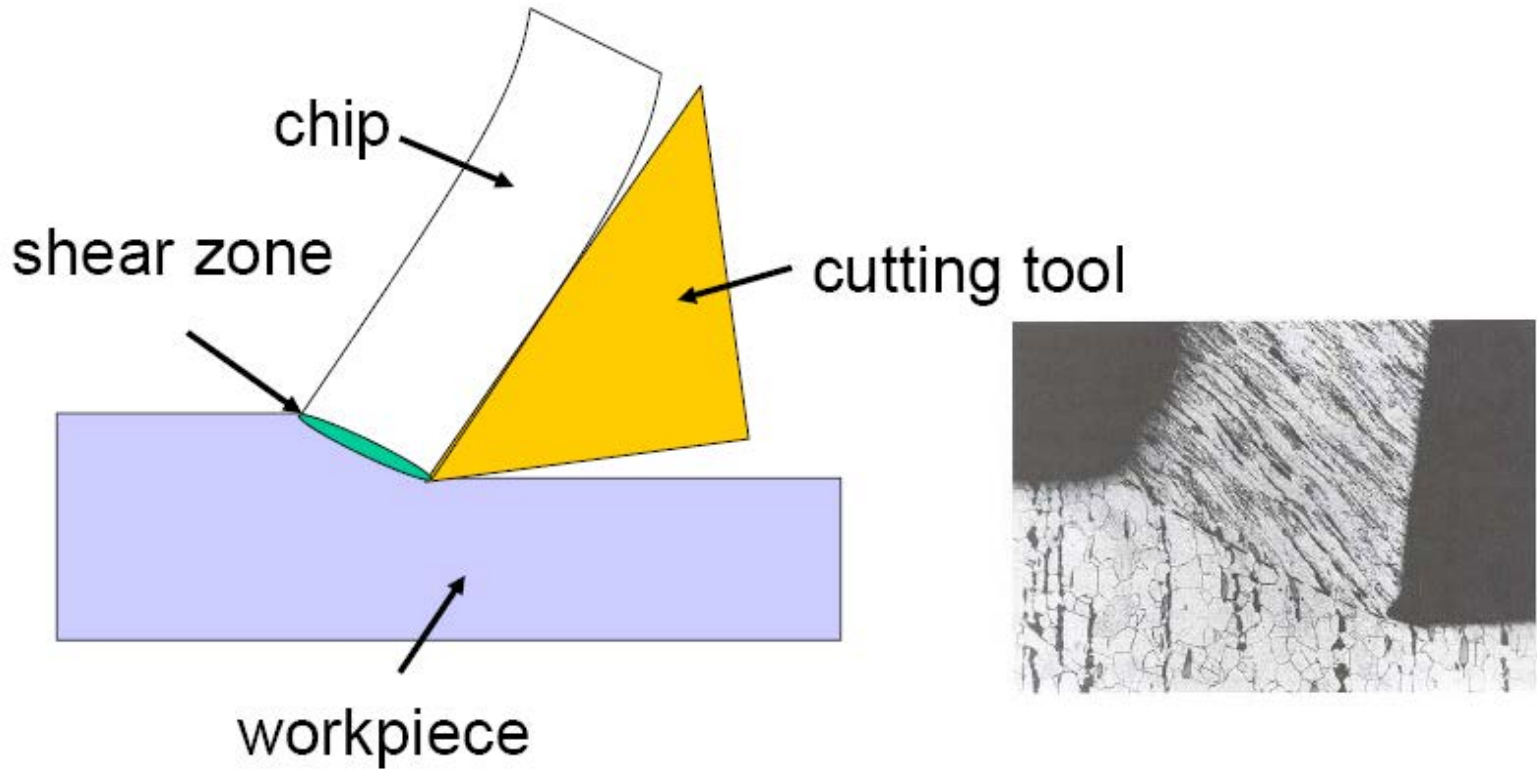



The Cutting Zone

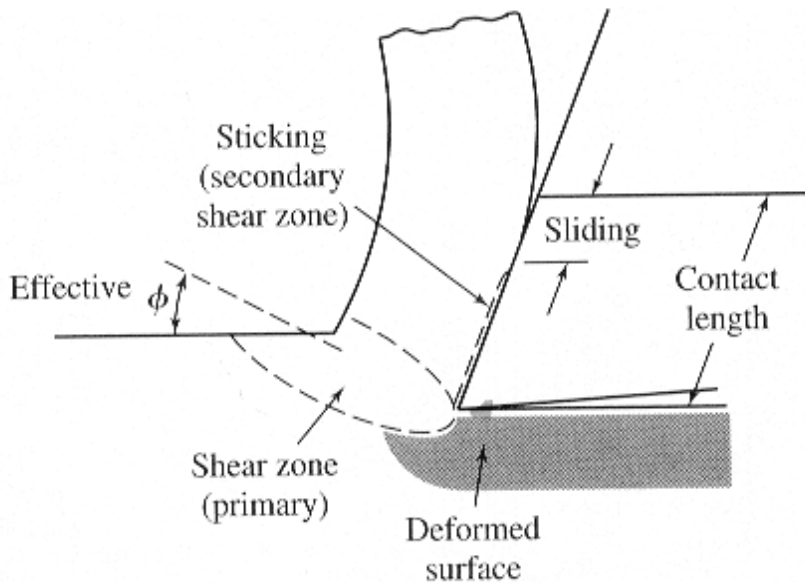

❖ *Primary shear zone:*

- In general, when n is large, primary shear zone becomes longer and wider, thus energy consumption increases.

❖ *Secondary shear zone*

- $\mu^*p > \tau_f$
- Sliding length is only 30%, the rest is shearing.

❖ *Tertiary shear zone*

- Upset and plowed by the tool edge, rubbing against the freshly formed surface.



Chip Formation Geometry

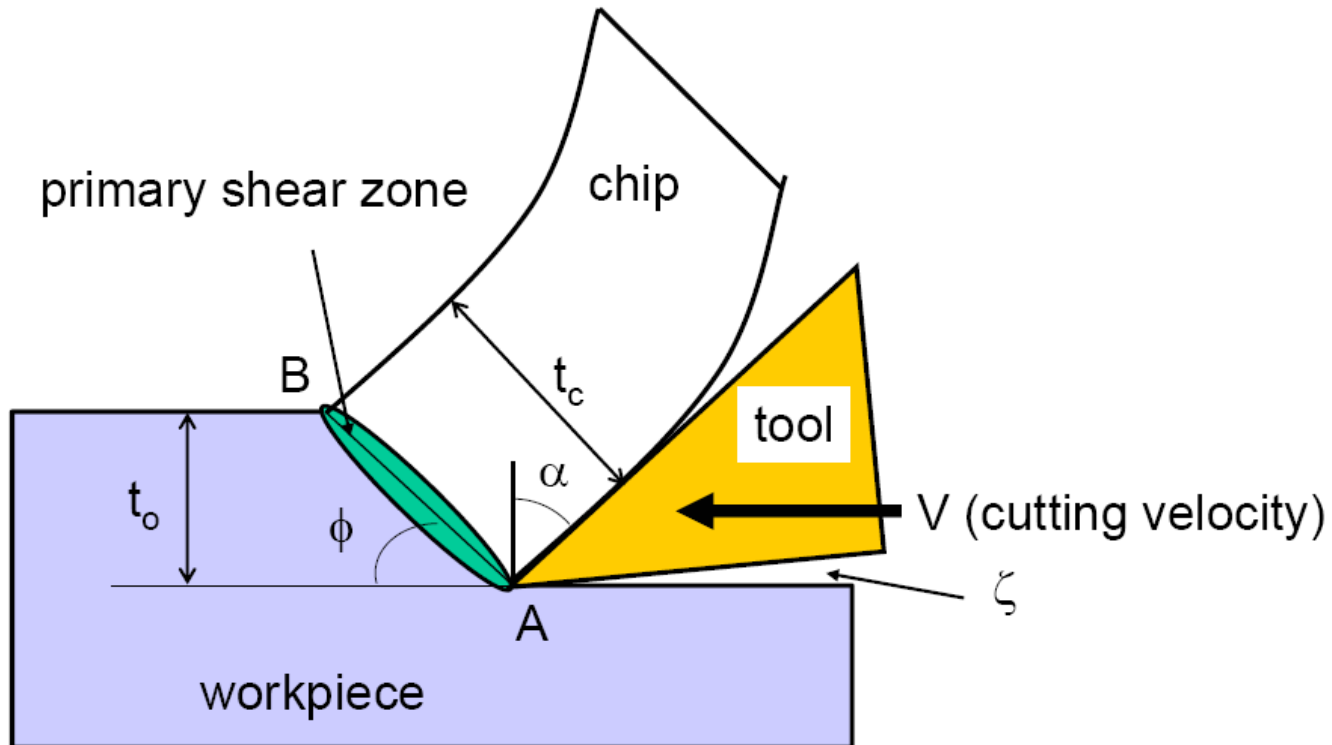



FORCES IN ORTHOGONAL CUTTING

- ❖ Resultant force
- ❖ Cutting speed
- ❖ Shear plane
- ❖ Rake face

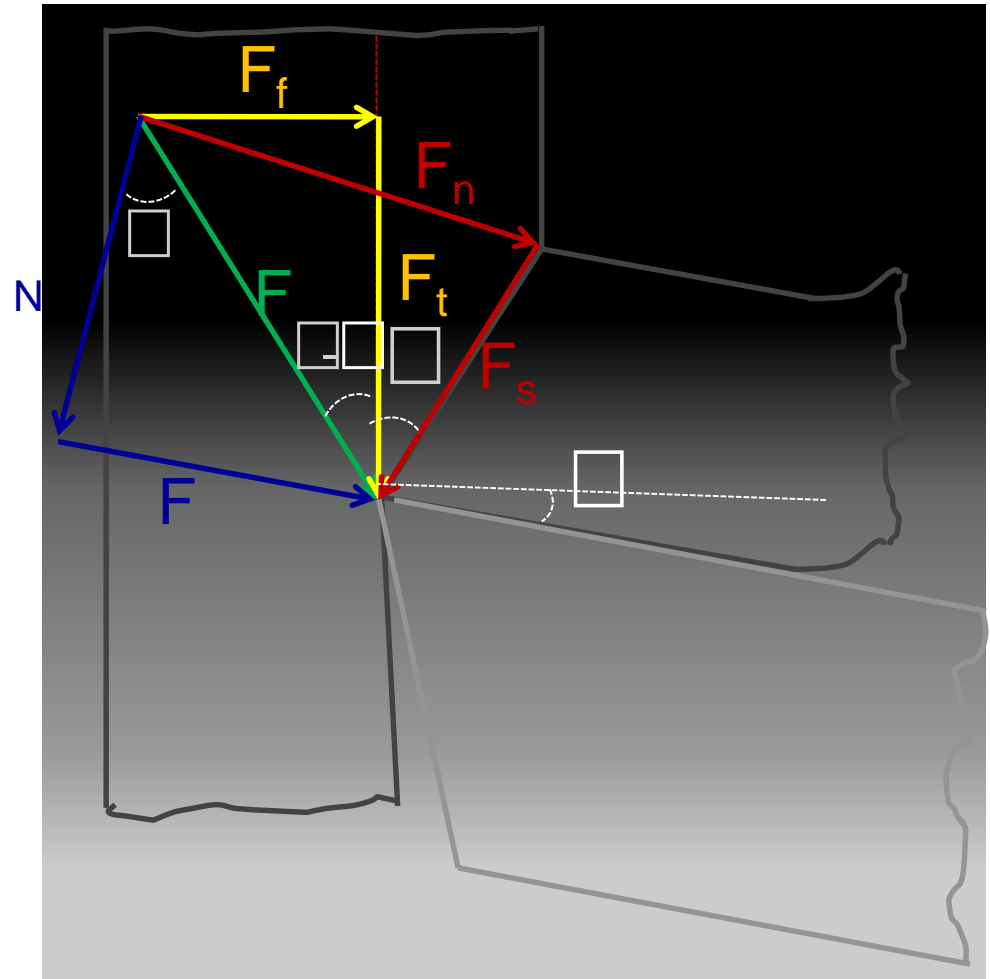



Shear Strain

- ❖ Unreformed chip section $A_0B_0A_1B_1$
- ❖ After shear becomes $A_1A_2B_1B_2$

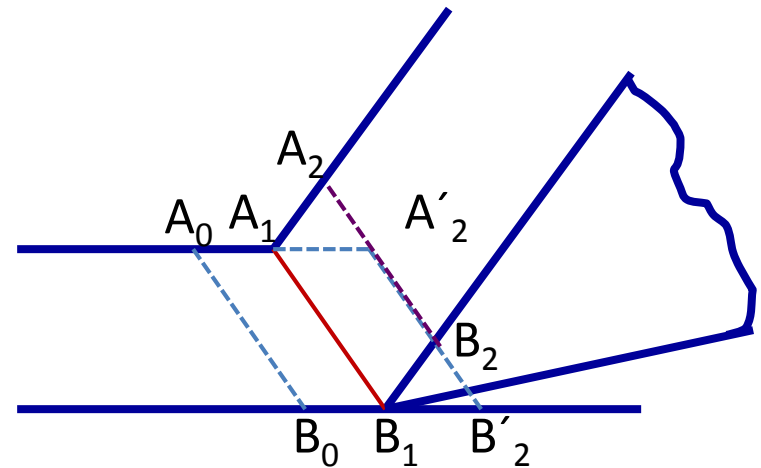



Shear Strain

❖ Plane strain $\rightarrow A'_2A_2=B'_2B_2$

$$\gamma_s = \frac{\Delta s}{\Delta d} = \frac{A'_2C + A_2C}{A_1C} = \cot \varphi + \tan(\varphi - \alpha)$$

$$\gamma_s = \frac{\cos \alpha}{\sin \varphi \cdot \cos(\varphi - \alpha)}$$

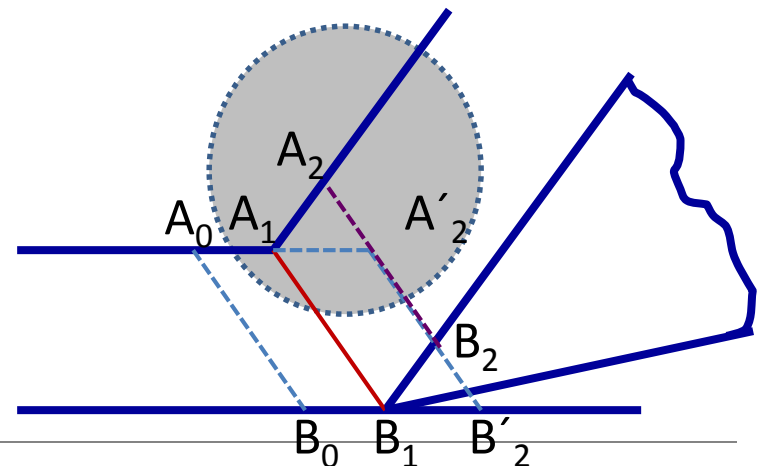
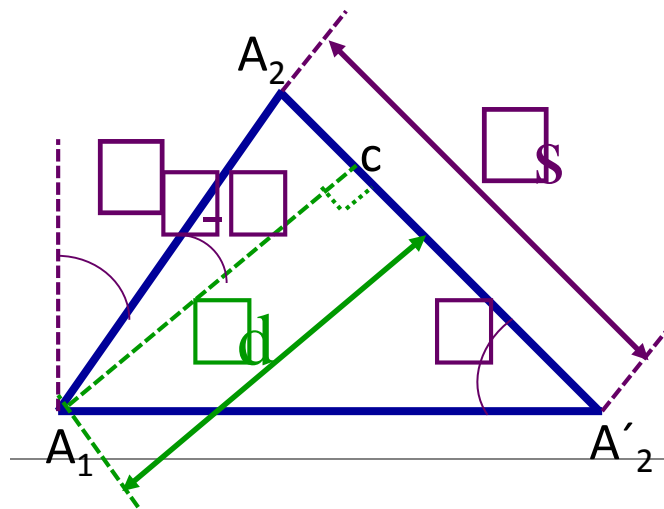



Strain Rate

$$\dot{\gamma}_s = \frac{\gamma_s}{\Delta t} = \frac{\Delta s}{\Delta d \cdot \Delta t} = \frac{V_s}{\Delta d}$$

$$\dot{\gamma}_s = \frac{V \cdot \cos \alpha}{\Delta d \cdot \cos(\varphi - \alpha)}$$



Card Model

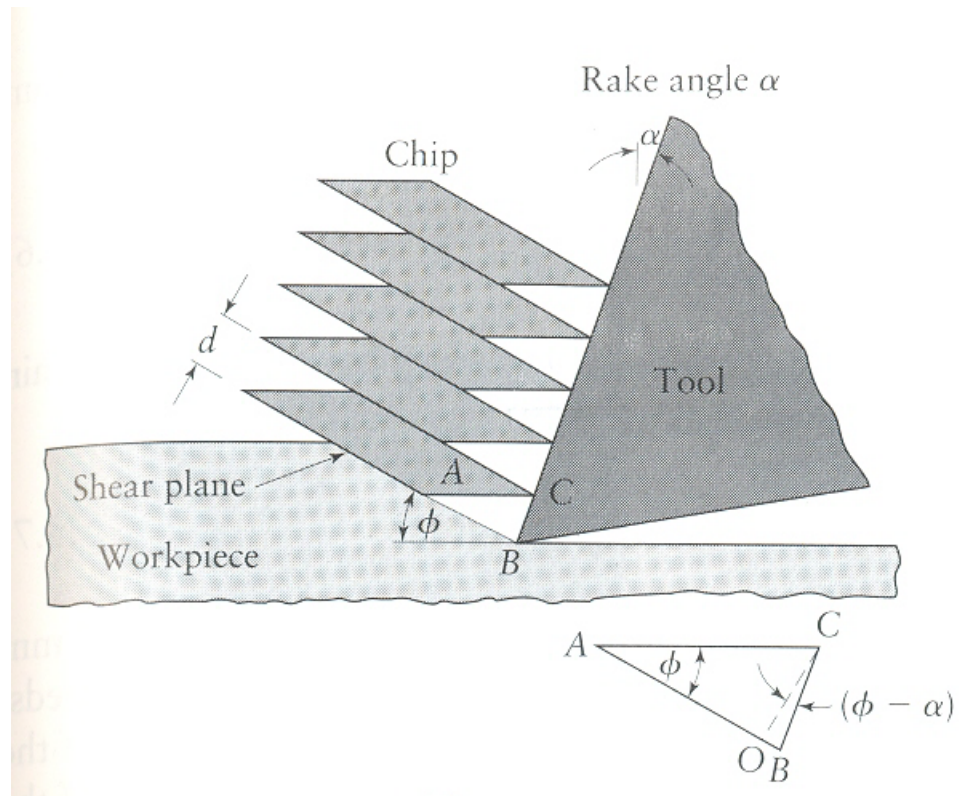



Shear Strain

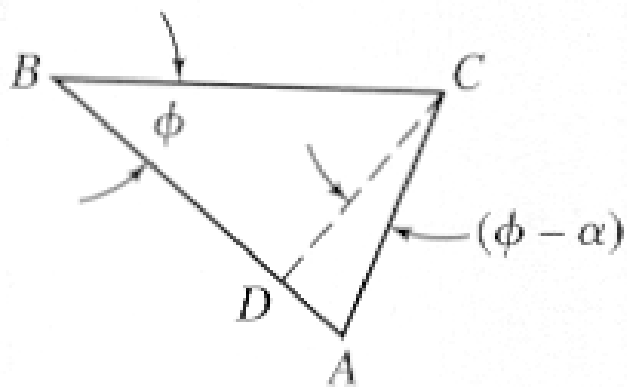
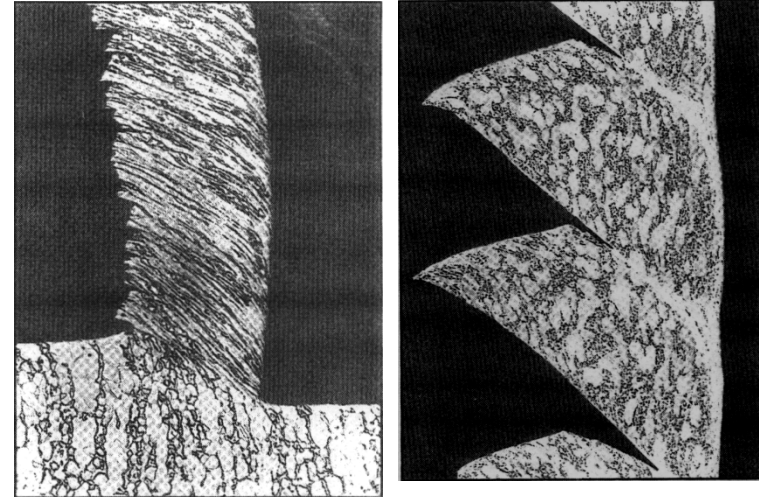
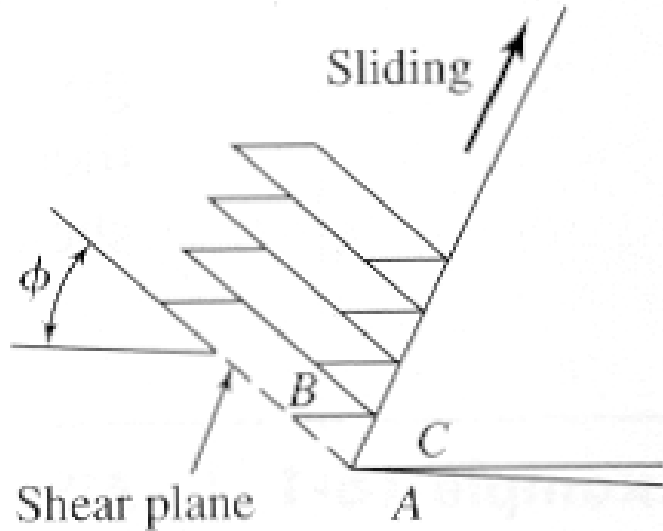

$$\begin{aligned}\gamma &= \frac{AB}{CD} = \frac{AD}{CD} + \frac{DB}{CD} \\ &= \tan(\phi - \alpha) + \cot \phi\end{aligned}$$



Shear Strain

- ❖ Large shear strain experienced with **low shear angle**
- ❖ Large shear strain with **low (or negative) rake angle**
- ❖ Strains as high as 5 in actual cutting operation
- ❖ Compare with bulk deform strain ($\epsilon = \ln$ at necking)

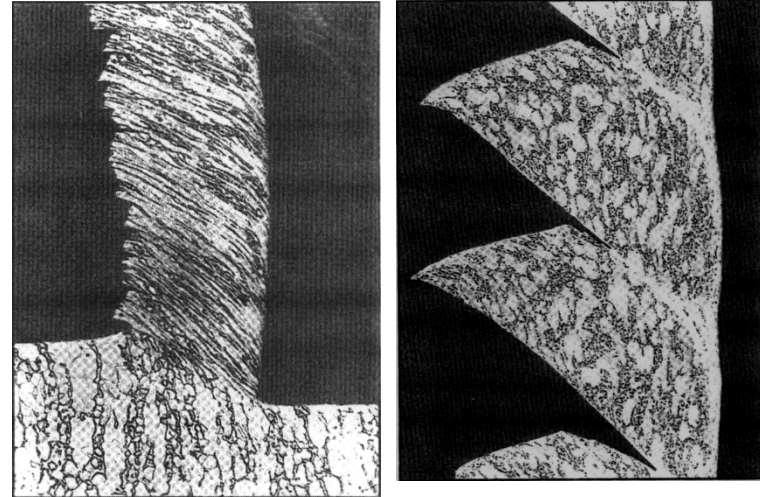

$$\begin{aligned}\gamma &= \frac{AB}{CD} = \frac{AD}{CD} + \frac{DB}{CD} \\ &= \tan(\phi - \alpha) + \cot \phi\end{aligned}$$



Shear Strain in Cutting

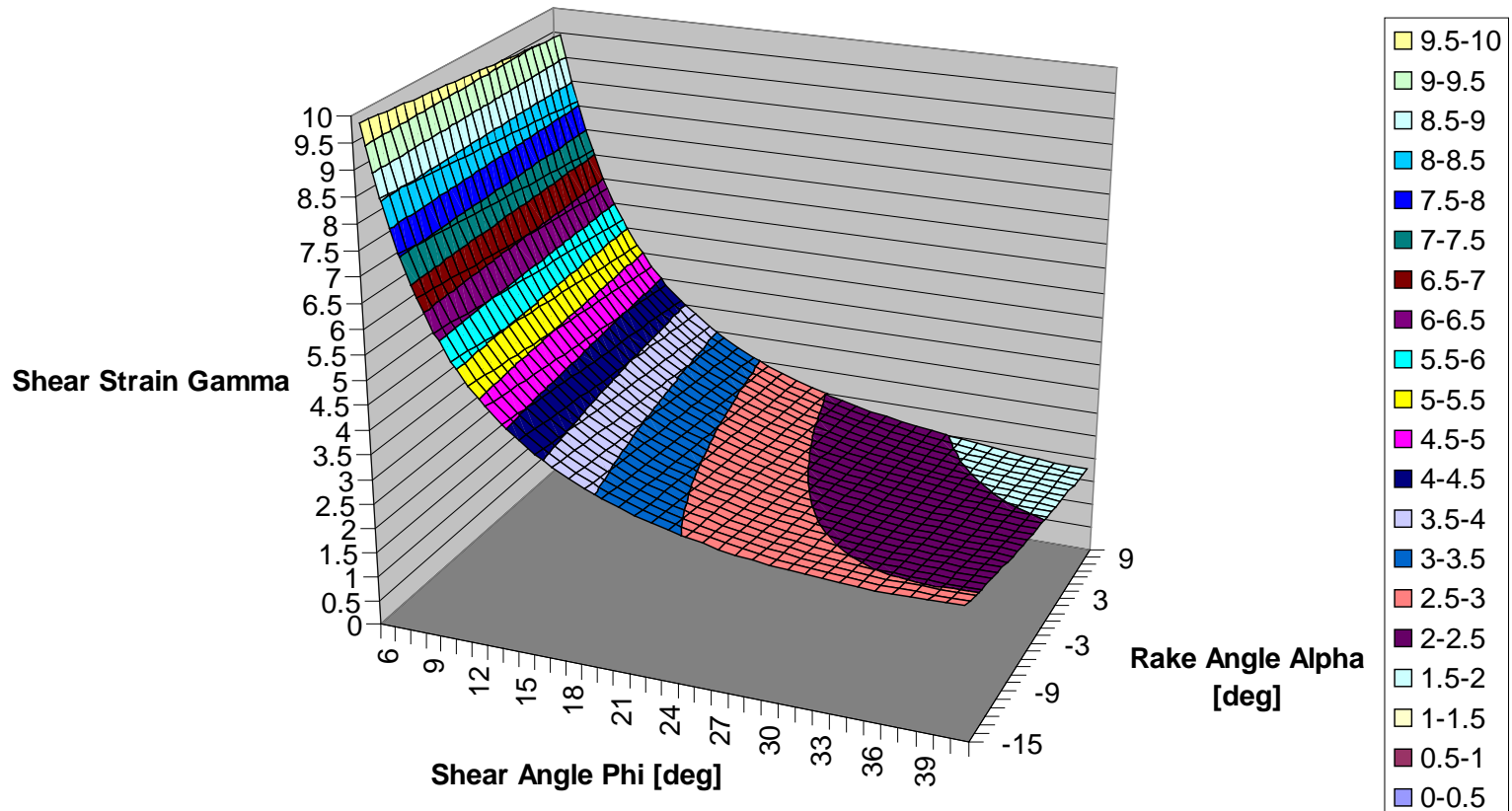



Shear Angle

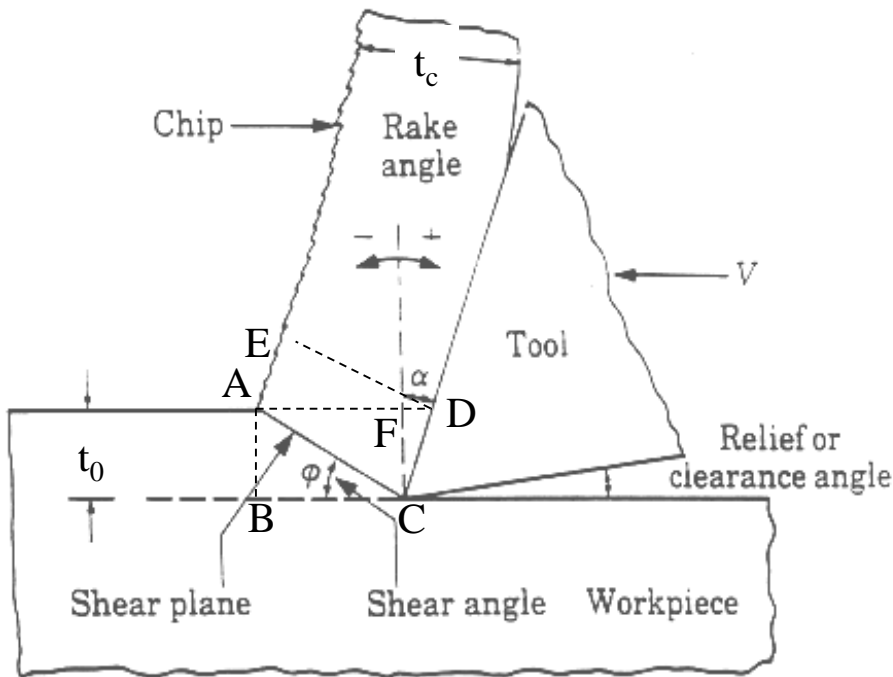

$$AD = \frac{DE}{\cos \alpha} = \frac{t_c}{\cos \alpha}$$

$$AD = AF + FD$$

$$AF = AD - DF$$

$$DF = CF \tan \alpha = t_0 \tan \alpha$$

$$AF = \frac{t_c}{\cos \alpha} - t_0 \tan \alpha$$

$$\tan \phi = \frac{AB}{BC} = \frac{AB}{AF} = \frac{t_0}{\frac{t_c}{\cos \alpha} - t_0 \tan \alpha}$$

$$\tan \phi = \frac{t_0 \cos \alpha}{t_c - t_0 \sin \alpha} = \frac{r_c \cos \alpha}{1 - r_c \sin \alpha}$$



Cutting Ratio

$$\text{From } \tan \varphi = \frac{r_c \cos \alpha}{1 - r_c \sin \alpha}$$

$$\tan \varphi - r_c \sin \alpha \tan \varphi = r_c \cos \alpha$$

$$r_c = \frac{\tan \varphi}{\sin \alpha \tan \varphi + \cos \alpha} = \frac{\sin \varphi}{\sin \varphi \sin \alpha + \cos \alpha \cos \varphi} = \frac{\sin \varphi}{\cos(\varphi - \alpha)}$$

Assuming part width does not change, volume constancy requires $t_0 l = t_c l_c$ where l is the chip length before cut and l_c the chip length after cut.

Therefore, $t_0 V = t_c V_c$, where v and v_s are cutting speed and chip flow speed, respectively. So we have

$$r_c = \frac{t_0}{t_c} = \frac{V_c}{V} = \frac{\sin \phi}{\cos(\phi - \alpha)}$$



Example 1

- ❖ Material is cut with a 10° rake tool at 400 ft/min. Cutting depth is 0.005", width of cut is 0.25" and the chip is measured to be 0.009" thick.
- ❖ Find cutting ratio and estimate the shear angle



Cutting Speeds

- ❖ Since $t_c > t_0$ then chip velocity must be less than cutting velocity by volume conservation

$$Vt_0 = V_c t_c$$

$$V_c = V \frac{t_0}{t_c} = Vr_c$$

$$V_c = V \frac{\sin \phi}{\cos(\phi - \alpha)}$$



Velocity Relationships

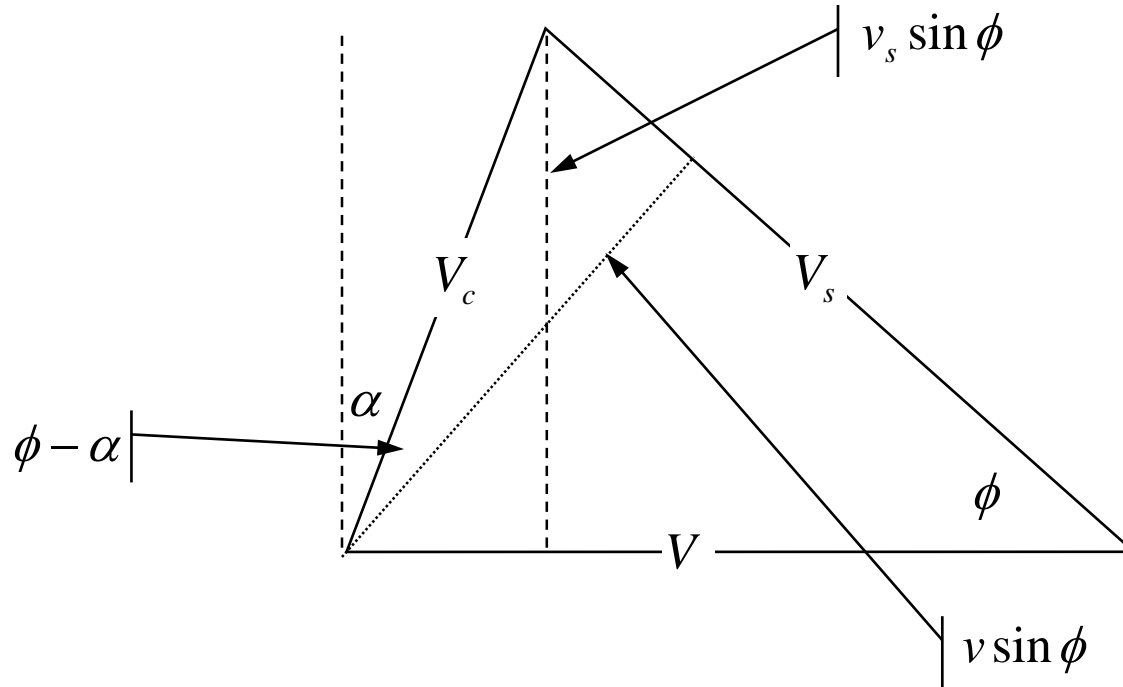

All v wrt base material

$$\frac{V_c}{\sin \phi} = \frac{V_s}{\cos \alpha} = \frac{V}{\cos(\phi - \alpha)}$$

V_s : سرعت حرکت ماده بر روی صفحه برش است



TIME OUT





Shear Strain Rate

$$\dot{\gamma} = \frac{V_s}{d}$$

$d \equiv$ shear zone thickness

$$d \approx 10^{-2} - 10^{-3} \text{ mm } (10^{-3} - 10^{-4} \text{ in.})$$

$$\dot{\gamma} \approx 10^{+3} - 10^{+6} \text{ sec}^{-1}$$

very high

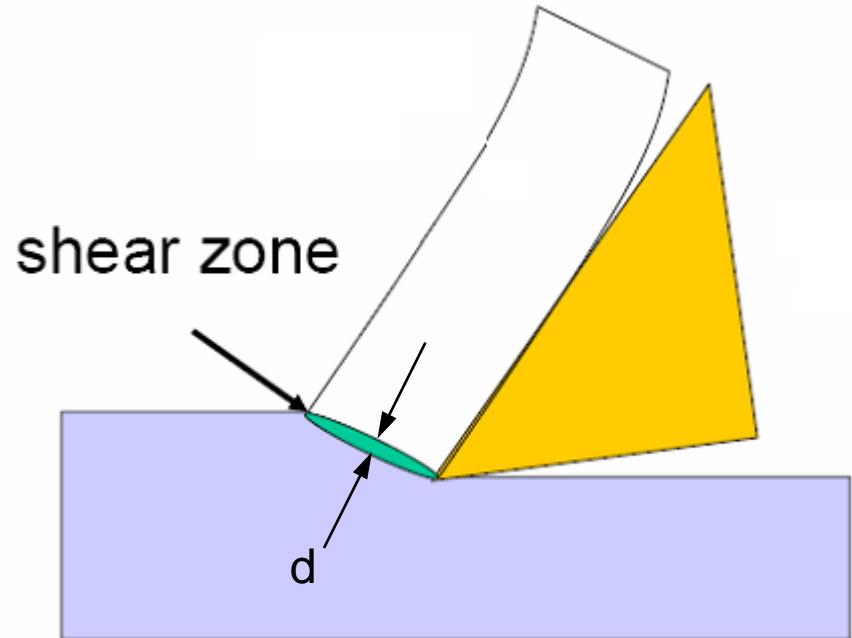

- ❖ Strain rate has a big effect on material strength & ductility
- ❖ This high strain rate creates residual stress in the machined surface and needs grinding operation to be removed



Forces in Cutting

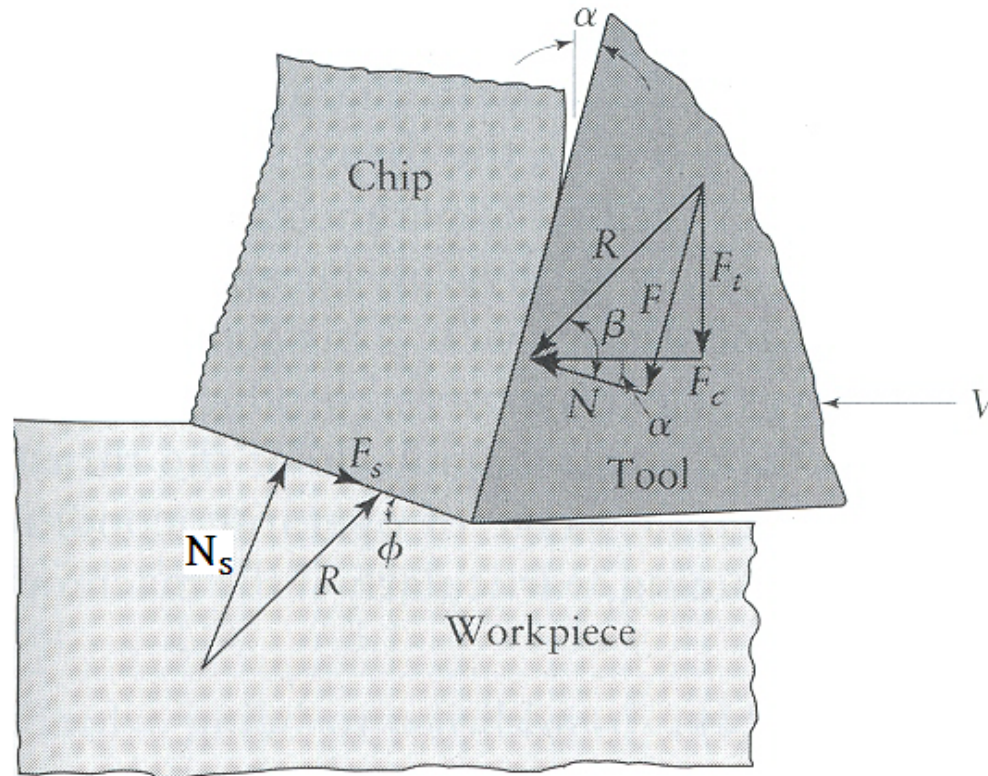



Forces in Cutting

❖ Merchant model

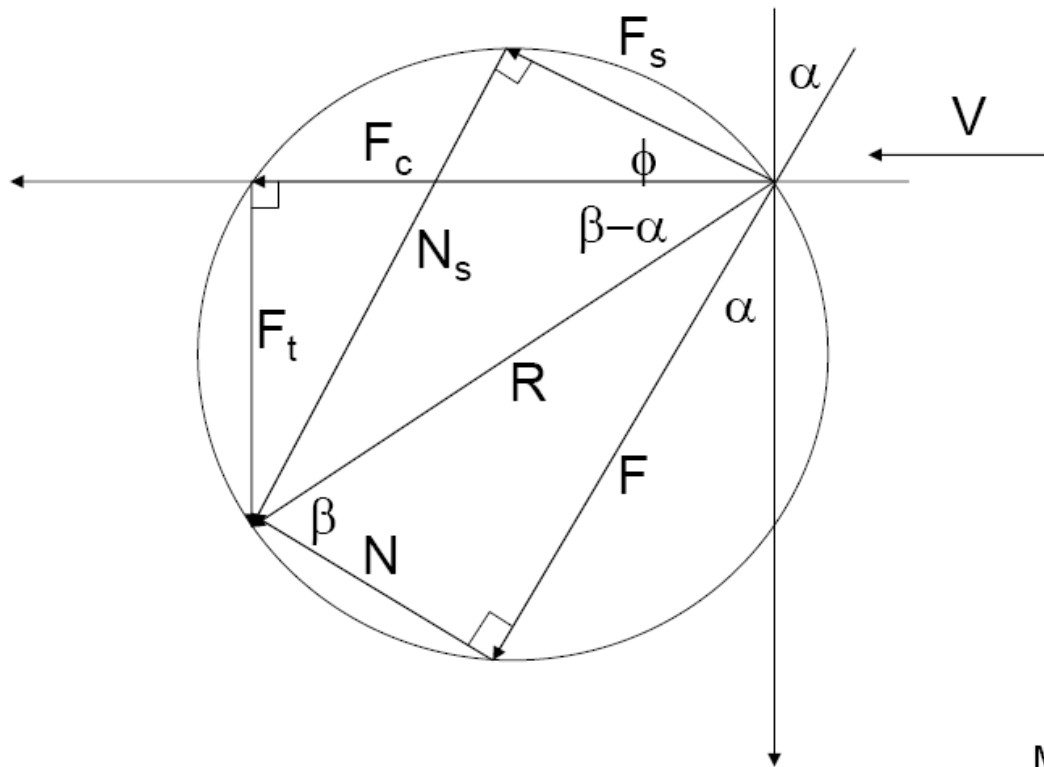

M. Eugene Merchant



Forces in Cutting

❖ Forces on Tool

- F_C = cutting force
- F_t = thrust force
- or
- F = friction force on tool face
- N = normal force on tool face

❖ Forces on Material

- F_s = shear force
- N_s = compressive force

❖ Angles

- α = rake angle (can be negative)
- β = friction angle
- ϕ = shear angle

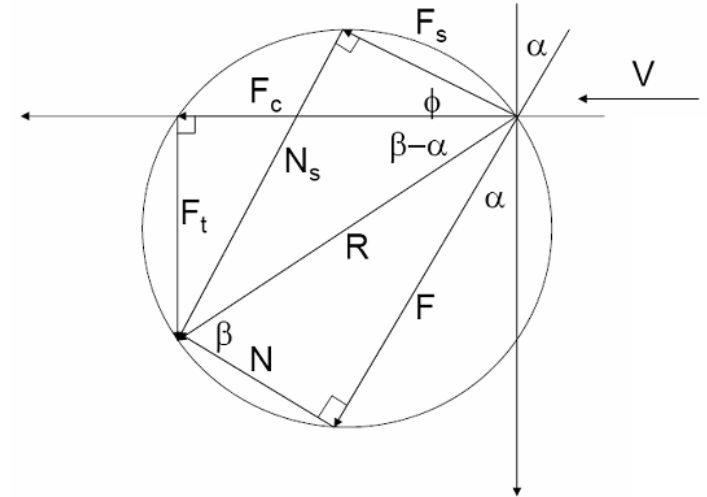



Force Relationships

- ❖ Relate immeasurable force components to the measurable ones (using dynamometers)

$$F = F_c \sin \alpha + F_t \cos \alpha$$

$$N = F_c \cos \alpha - F_t \sin \alpha$$

$$F_s = F_c \cos \phi - F_t \sin \phi$$

$$N_s = F_c \sin \phi + F_t \cos \phi$$

$$- \mu = \operatorname{tg} \beta = \frac{F}{N}$$

- ❖ If cutting and thrust forces are known, we can estimate friction and shear forces
- ❖ What about shear angle?



Shear Angle Relationships

❖ Merchant

$$\tau = \frac{F_s}{A_s} = \frac{F_c \sec(\beta - \alpha) \cos(\phi + \beta - \alpha) \sin \phi}{wt_0}$$

$$\frac{d\tau}{d\phi} = \cos(\phi + \beta - \alpha) \cos \phi - \sin(\phi + \beta - \alpha) \sin \phi = 0$$

$$\phi = 45^\circ + \frac{\alpha}{2} - \frac{\beta}{2}$$

❖ Slipline

$$\phi = 45^\circ + \alpha - \beta$$

❖ Empirical (Sata & Minuzo)

$$\phi = \begin{cases} \alpha, & \alpha \leq 15^\circ \\ 15^\circ, & \text{otherwise} \end{cases}$$



Friction Relationships

$$F = R \sin \beta$$

$$N = R \cos \beta$$

❖ Friction along tool face

$$\mu = \frac{F}{N}$$

$$\mu = \tan \beta = \frac{F_t + F_c \tan \alpha}{F_c - F_t \tan \alpha}$$

μ generally 0.5 – 2 for cutting

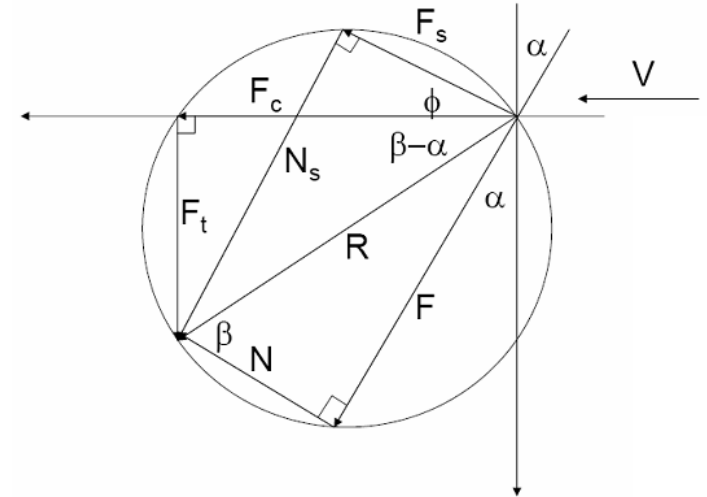



Cutting Zone Stress

- ❖ Assume stresses in the shear plane and in the tool-chip interface are uniformly distributed
- ❖ Shear plane area

$$A_s = \frac{wt_0}{\sin \phi}$$

- ❖ Average shear stress

$$\tau = \frac{F_s}{A_s} = \frac{F_s \sin \phi}{wt_0}$$

- ❖ Average normal stress

$$\sigma = \frac{N_s}{A_s} = \frac{N_s \sin \phi}{wt_0}$$



Force Estimation by Material Strength

- ❖ If material strength S is known, F_s can be estimated and therefore F_c and F_t can be estimated:

$$\tau = \frac{F_s}{A_s}$$

$$F_s = SA_s = Swt_c = Sw \frac{t_0}{\sin \phi}$$

$$F_c = \frac{F_s \cos(\beta - \alpha)}{\cos(\phi + \beta - \alpha)} = \frac{Sw t_0 \cos(\beta - \alpha)}{\sin \phi \cos(\phi + \beta - \alpha)}$$

$$F_t = \frac{F_s \sin(\beta - \alpha)}{\cos(\phi + \beta - \alpha)} = \frac{Sw t_0 \sin(\beta - \alpha)}{\sin \phi \cos(\phi + \beta - \alpha)}$$



Forces in Cutting

❖ Cutting force F_c

- increases with material strength
- increases with increasing depth of cut
- increases with decreasing rake angle
- increases with decreasing speed
 - ◆ as speed decreases, shear angle decreases and μ increases

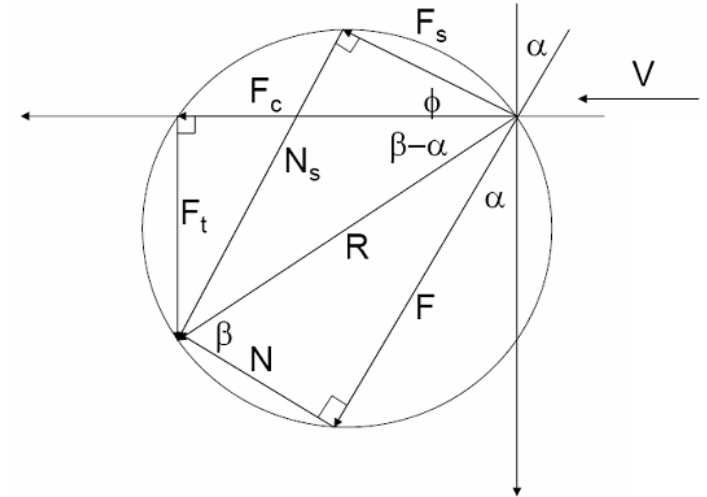



Forces in Cutting

❖ Thrust force

- does no work to cut material
- used to evaluate if machine is adequately strong/stiff

$$F_t = R \sin(\beta - \alpha)$$

$$F_t = F_c \tan(\beta - \alpha)$$

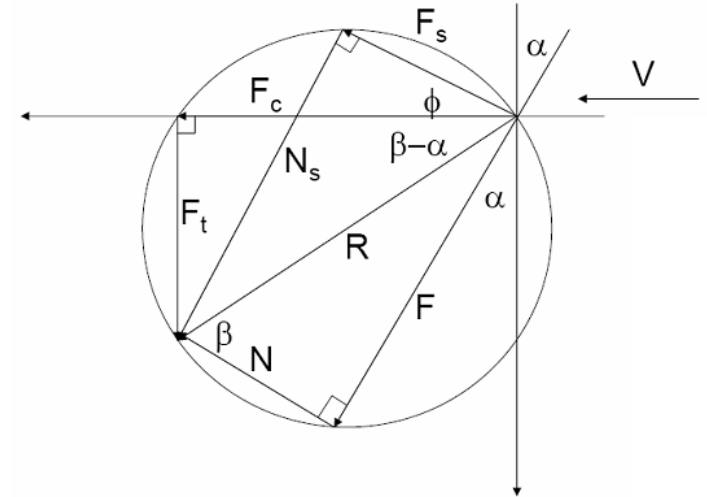



Forces in Cutting

- ❖ Shear force (and cutting energy) increases when shear angle decreases, i.e, when friction increases and rake angle decreases.

$$\phi = 45^\circ + \alpha - \beta$$

- ❖ Thrust force decreases when friction decreases and rake angle increases.



Rake Face Stress

- ❖ Difficult to determine due to
 - Stresses not being uniformly distributed
 - Contact length being difficult to determine (and therefore area of action)



TIME OUT





Cutting Power

- ❖ Specific cutting energy (**energy per volume**) just like specific deformation energy u
- ❖ Typical of material
- ❖ Total power related to u just like deformation

$$\text{---} W = u \cdot \text{volume} \text{---} \text{ (typ. no fixed volume)}$$

$$P = u \cdot MRR = \left[\frac{\text{work}}{\text{vol}} \cdot \frac{\text{vol}}{\text{time}} = \frac{\text{work}}{\text{time}} = \text{power} \right]$$



Cutting Power

❖ Example specific cutting energies

- Steel $u=2.7-9.3 \text{ W-s/mm}^3 = 1.0-3.4 \text{ hp-min/in}^3$
- Stainless steel $u=3.0-5.2 \text{ W-s/mm}^3 = 1.1-1.9 \text{ hp-min/in}^3$
- Titanium $u=3.0-4.1 \text{ W-s/mm}^3 = 1.1-1.5 \text{ hp-min/in}^3$
- Magnesium $u=0.4-0.6 \text{ W-s/mm}^3 = 0.15-0.2 \text{ hp-min/in}^3$



Cutting Power

- ❖ Power related to *cutting* force

$$P = F_c V$$

- ❖ TOTAL specific power (energy per unit volume)

$$u_t = \frac{\text{work / time}}{\text{volume / time}} = \frac{\text{power}}{\text{volume rate}} = \frac{F_c v}{wt_0 v} = \frac{F_c}{wt_0}$$



Cutting Power

- ❖ total composed of SHEAR and FRICTION power

$$u_t = u_s + u_f$$

$$u_s = \frac{F_s v_s}{wt_0 v}$$

$$u_f = \frac{F v_c}{wt_0 v} = \frac{Fr}{wt_0} = \frac{(F_c \sin \alpha + F_t \cos \alpha) r}{wt_0}$$

- ❖ Also includes surface formation energy and momentum change of chip, but these are typically negligible



Summary: Factors Affecting Machining

TABLE 20.1

Parameter	Influence and interrelationship
Cutting speed, depth of cut, feed, cutting fluids	Forces, power, temperature rise, tool life, type of chip, surface finish.
Tool angles	As above; influence on chip flow direction; resistance to tool chipping.
Continuous chip	Good surface finish; steady cutting forces; undesirable in automated machinery.
Built-up edge chip	Poor surface finish; thin stable edge can protect tool surfaces.
Discontinuous chip	Desirable for ease of chip disposal; fluctuating cutting forces; can affect surface finish and cause vibration and chatter.
Temperature rise	Influences tool life, particularly crater wear, and dimensional accuracy of workpiece; may cause thermal damage to workpiece surface.
Tool wear	Influences surface finish, dimensional accuracy, temperature rise, forces and power.
Machinability	Related to tool life, surface finish, forces and power.



با تشکر از توجه شما