

مسائل زیر را تنها به روش ترسیمی حل نمایید.

- 2.13. A student wishes to design a four-bar linkage that will store a bicycle above his bed. Two positions of the storage rack are shown in Fig. P2.4. Find acceptable ground and moving pivots for this design objective.

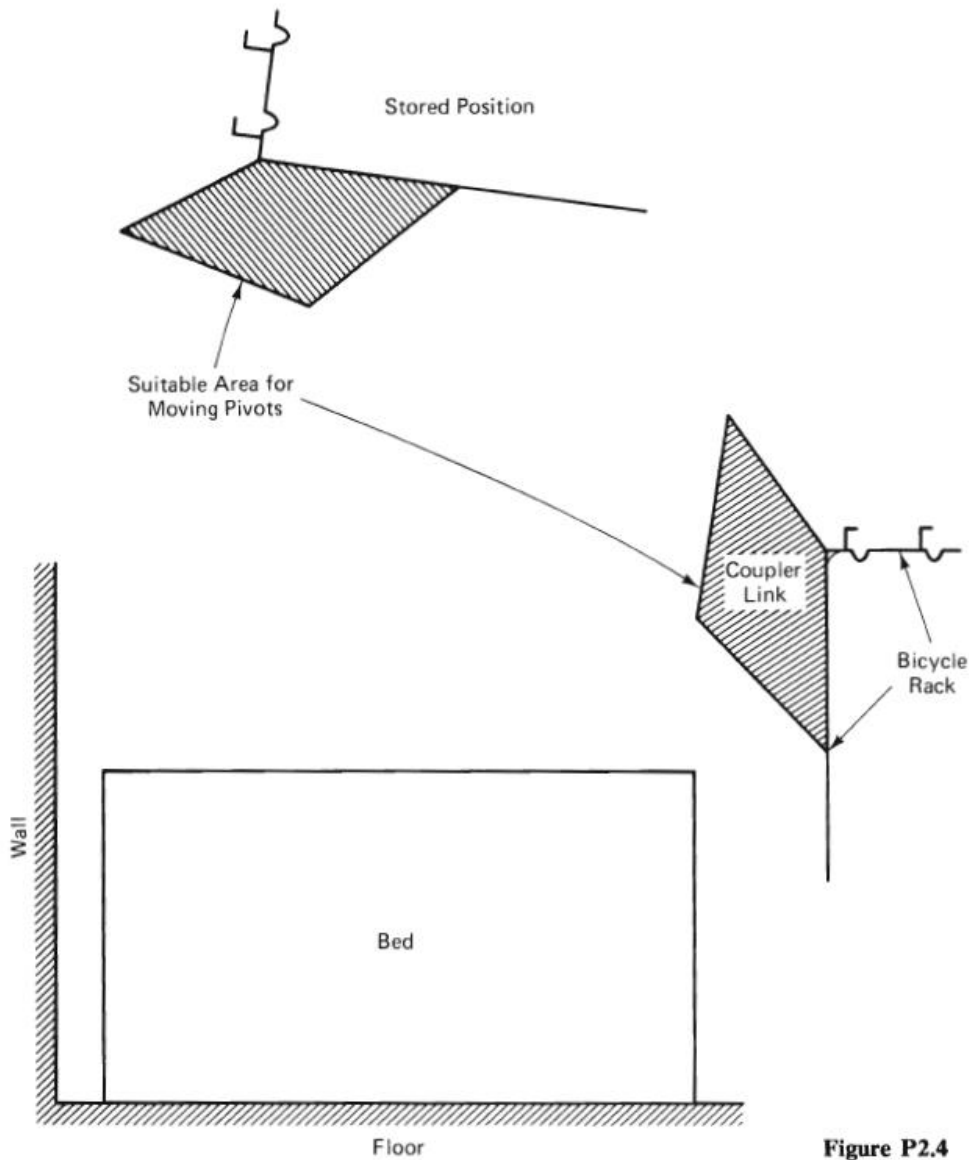

Figure P2.4

- 2.16. As part of an automation process, a four-bar linkage must be designed to remove boxes from one conveyor belt and deposit them on an upper conveyor belt as shown in Fig. P2.7 (three prescribed positions). Both ground and moving pivots must be located between the upper and lower conveyor belts.
- Design an acceptable four-bar by the graphical method.
  - Design an acceptable four-bar by the complex-number method.
  - Design an acceptable four-bar by the ground-pivot specification method.

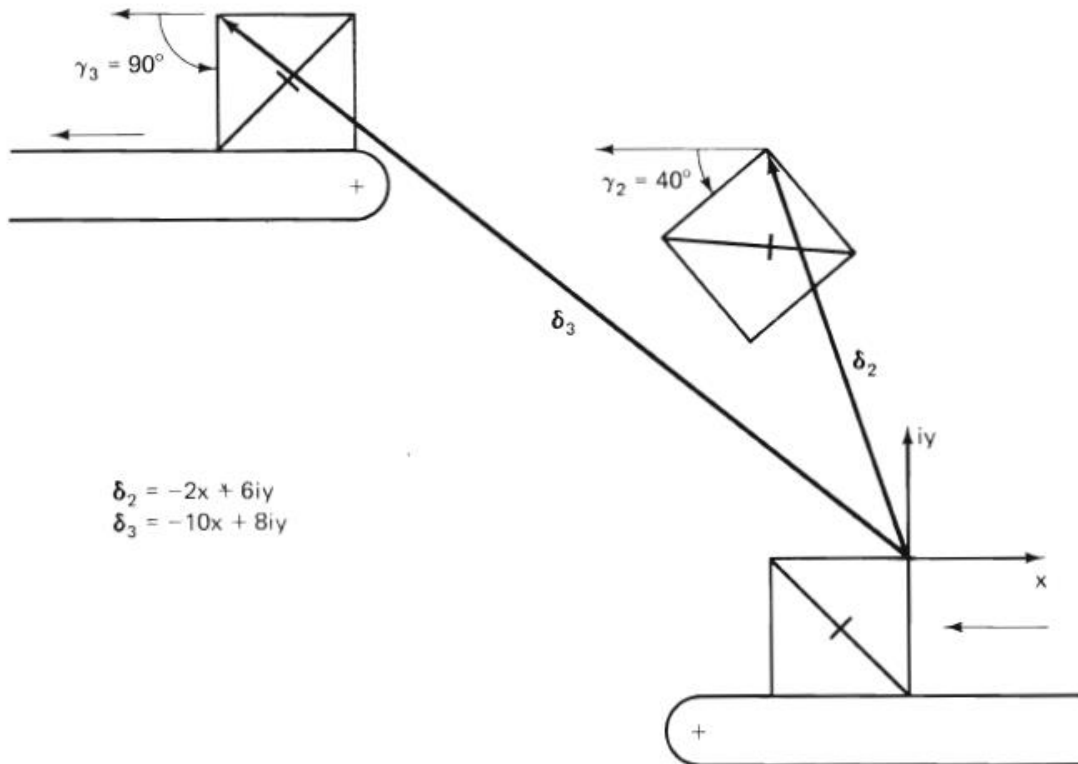

Figure P2.7

- 2.22. A four-bar path generator (with prescribed timing) is required as part of an arm-actuated propulsion system for the wheelchair in Fig. P2.13. The three prescribed path points shown have been determined to be the most efficient arm motion by a set of patients. This movement of the coupler path point ( $C_1, C_2, C_3$ ) provides the input, while the output is a rotation of the large wheel with a ground pivot at  $A_0$ . (A clutch located at  $A_0$  will slip when the patient returns from  $C_3$  to  $C_1$  along the same path.) The other ground pivot  $B_0$  is specified as well as the rotations of the wheel-driving link  $A_0A$  ( $\phi_2 = 38^\circ$  cw,  $\phi_3 = 80^\circ$  cw). By the graphical method, find the initial position of an acceptable four-bar linkage for this task.

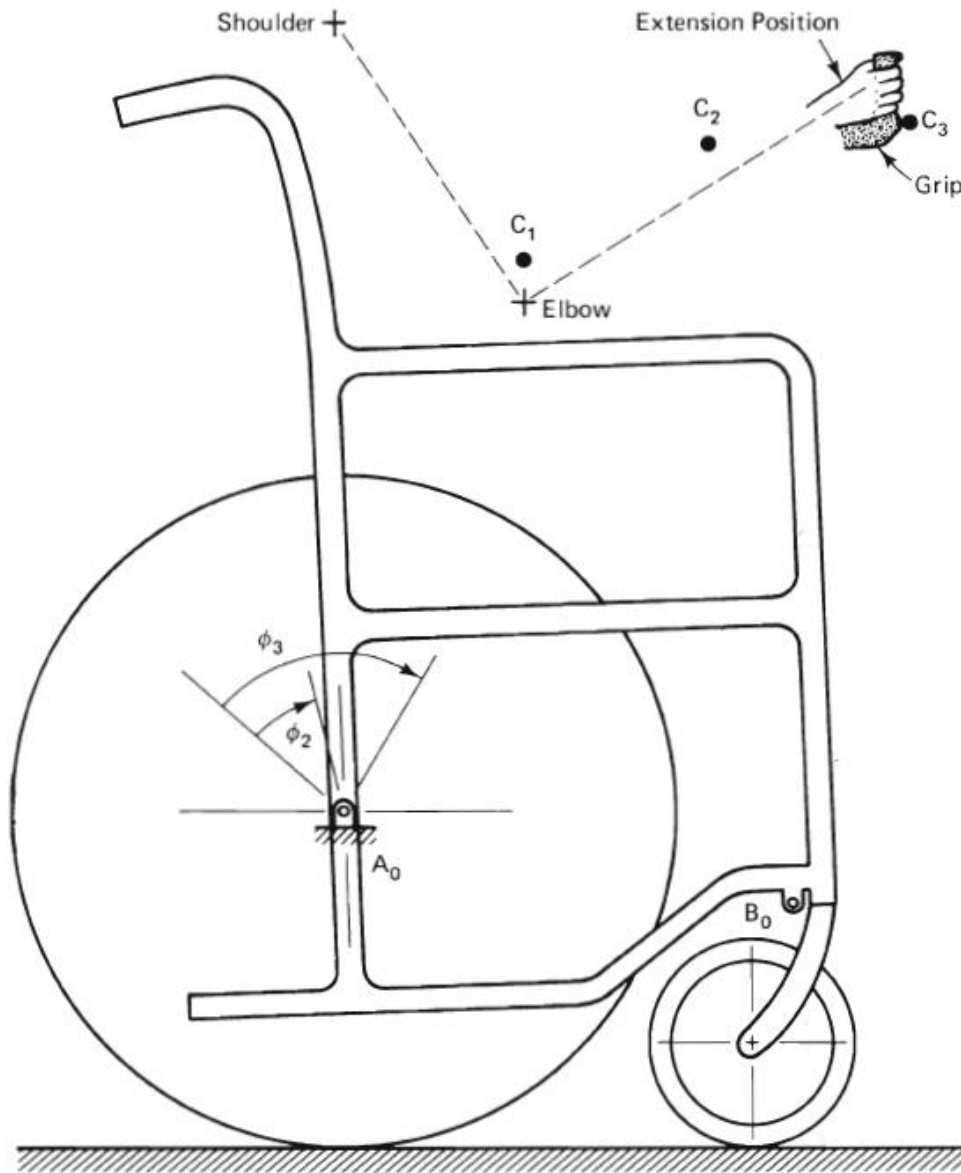
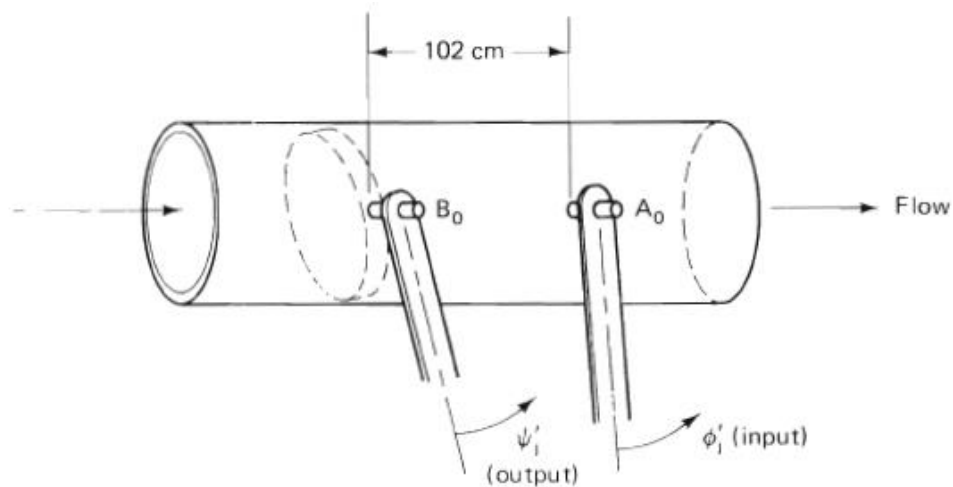
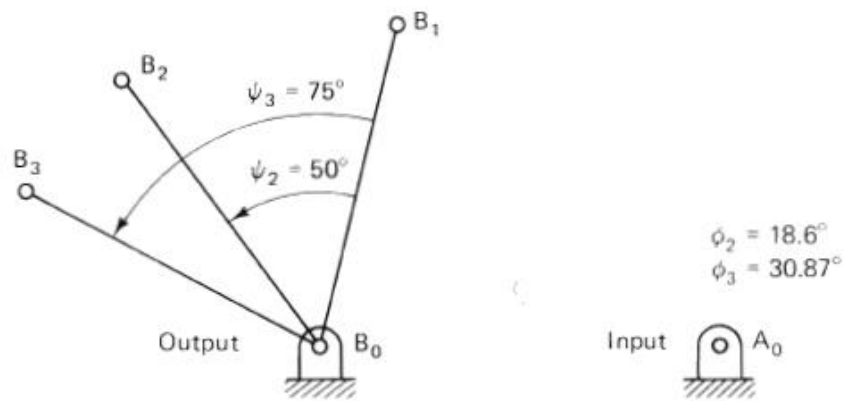

Figure P2.13

- 2.26. Figure P2.17a shows a butterfly valve in a tube that has a liquid flowing through it. A four-bar function generator is to be designed so that movement of the input link ( $A_0A$ ) in equal increments will produce equal incremental changes of the flow through the butterfly valve (the output). Figure P2.17b shows the angles required for this objective ( $\phi_2$ ,  $\phi_3$ ,  $\psi_2$ , and  $\psi_3$ ) as well as the location of  $B_0$ ,  $B$ , and  $A_0$ .
- Using the graphical method of Fig. 2.49, find the location of point  $A$ .
  - Use the overlay technique to find point  $A$ .
  - Use the loop-closure method to find point  $A$ .
  - Use Freudenstein's equation to solve for this linkage ( $\phi_1 = 128.5^\circ$ ).



(a)



(b)

Figure P2.17