

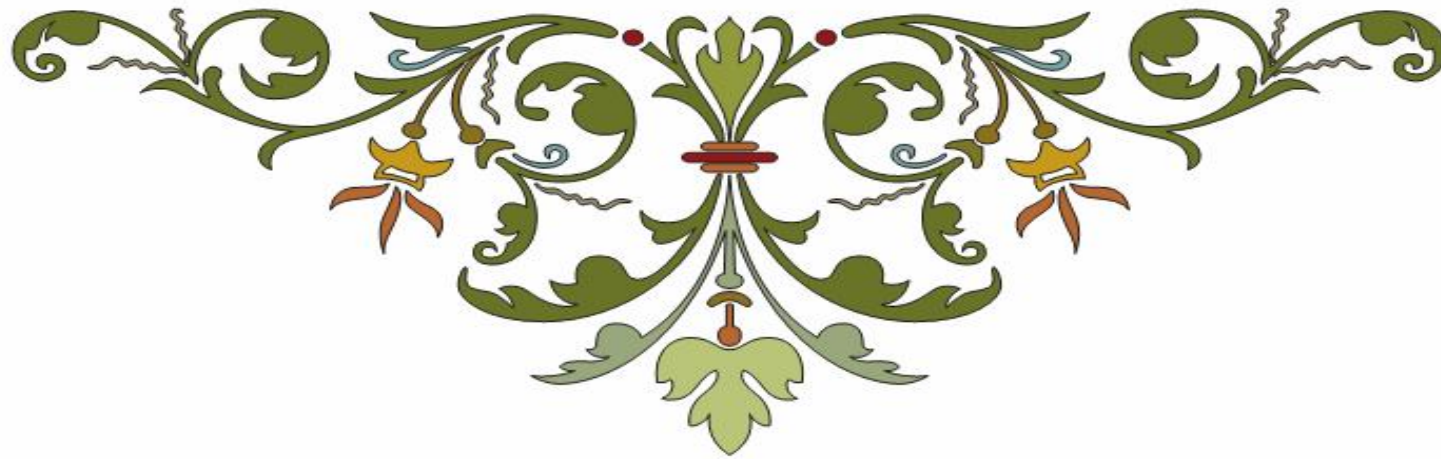

In the Name of God



Fruit Breeding

M. Gholami





Methods in Fruit Breeding
by [James N. Moore](#) (Author) ,
[Jules Janick](#) (Author)

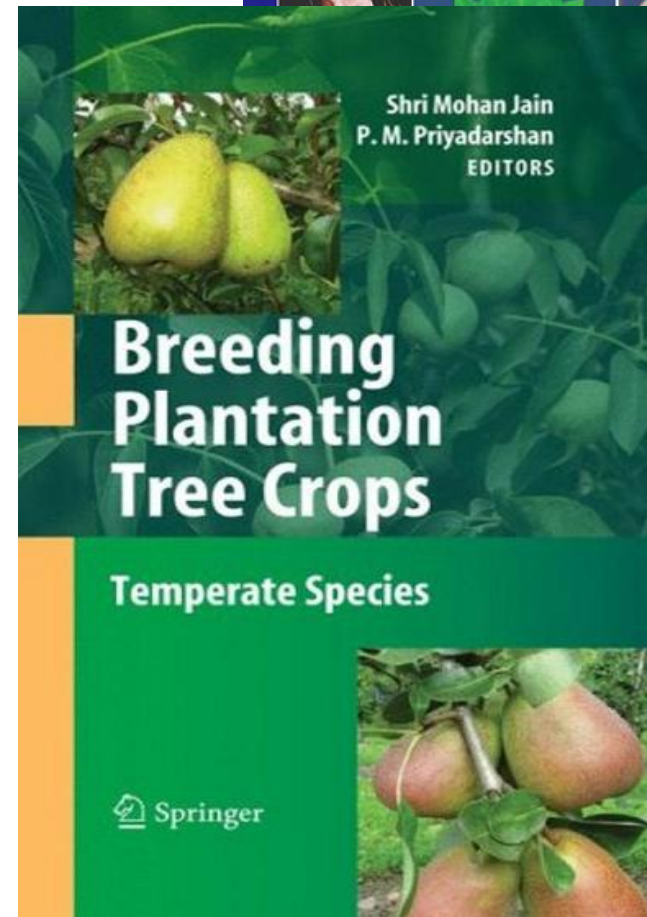
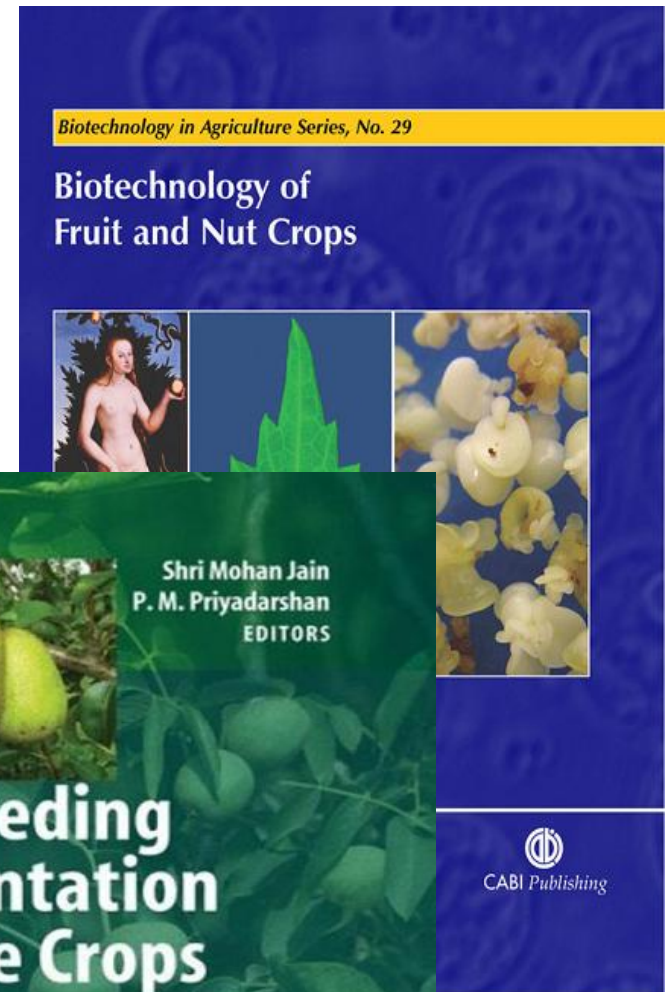
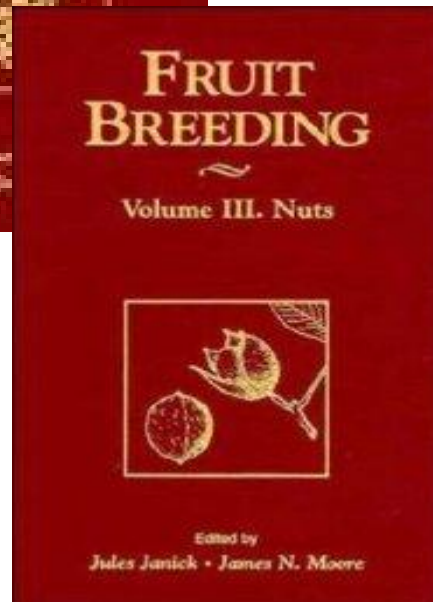
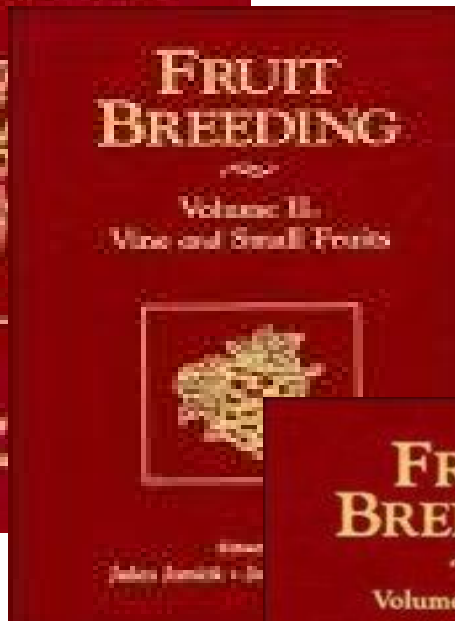
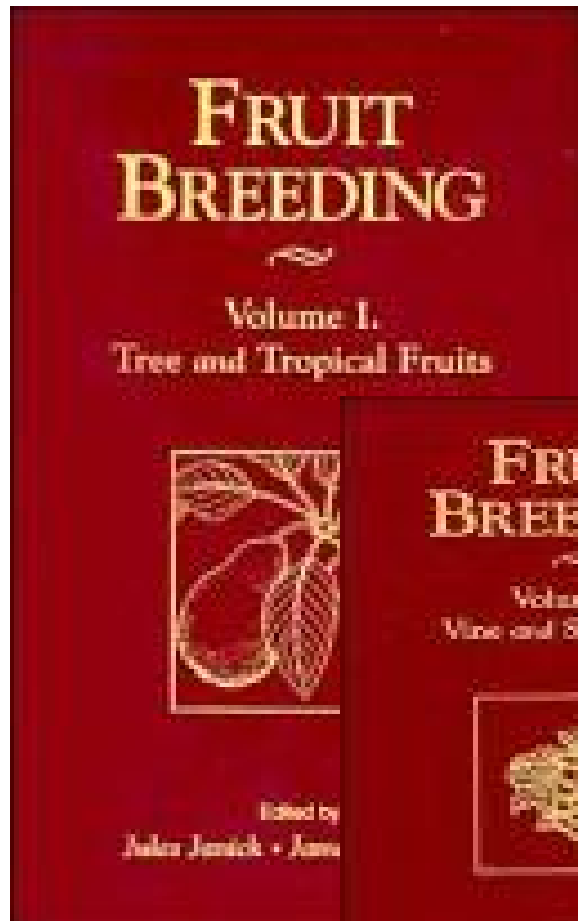

HYBRIDIZATION

Ø Hybridization

The formation of a new organism by normal sexual processes or by protoplast fusion

ü Wide Hybridization (Interspecific Hybridization)

Crosses made between distantly related species or genera

ü Somatic hybridization (Protoplast fusion)

Crosses made between somatic cells

► One of the most effective methods of crops improvement programs

Pollination and Fertilization

- ü For pollen sperm to successfully fertilize the egg, there must be **pollination**: a method to get the pollen from the male anther to the stigma.
- ü Pollen sticks to the stigma, starts growing a pollen tube
- ü **Fertilization** begins when tube begins to grow toward the egg

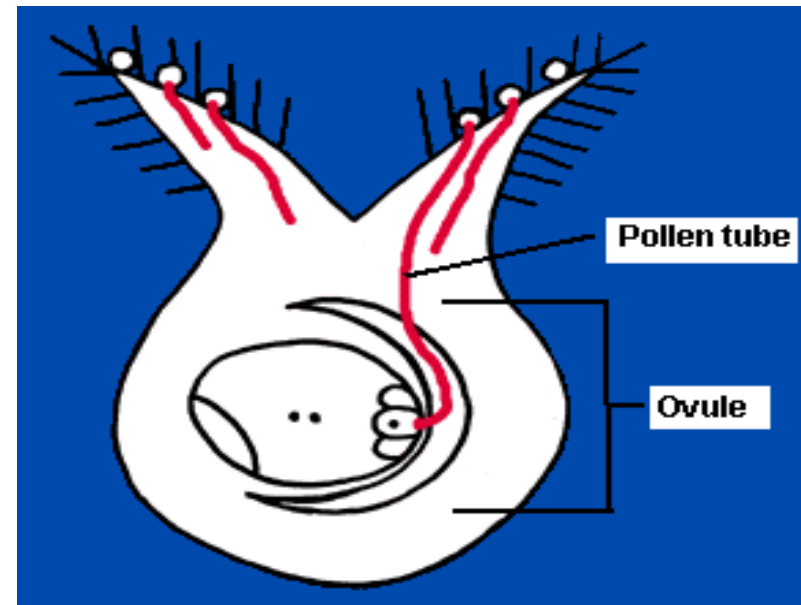
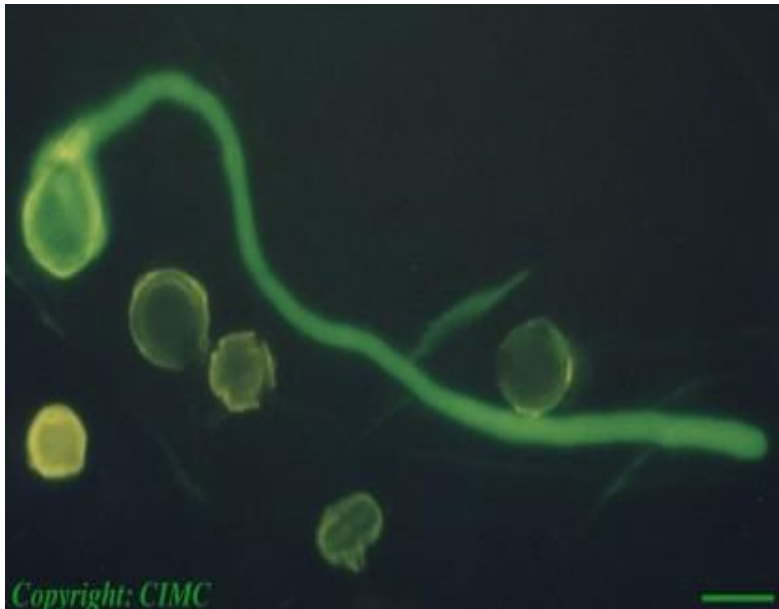

Double Fertilization

- Double fertilization occurs: One sperm nucleus ($1n$) fertilizes the egg, producing a zygote ($2n$) which becomes the plant embryo inside the seed
- Another sperm nucleus fuses with the polar nuclei, resulting in a triploid endosperm ($3n$)
- Endosperm is a source of food for the young embryo.

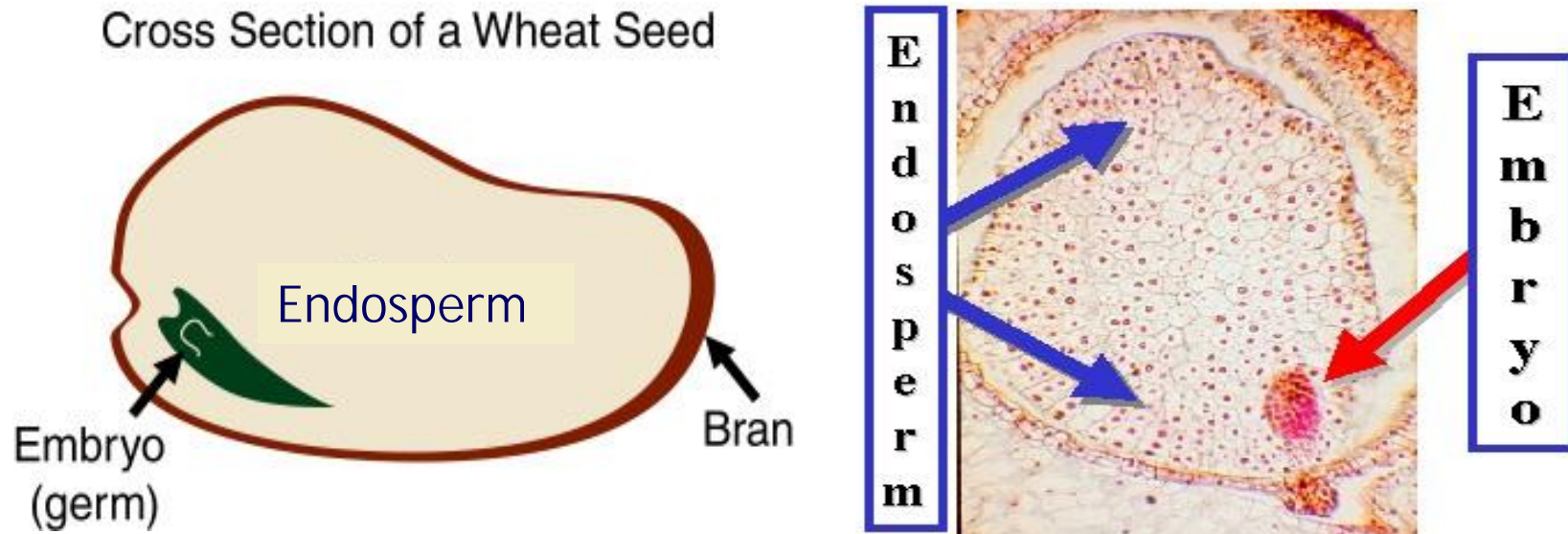

If

Autogamy

- Self-fertilization
- Pollen transfer within or among flowers of same individual
- ~25% of plant taxa

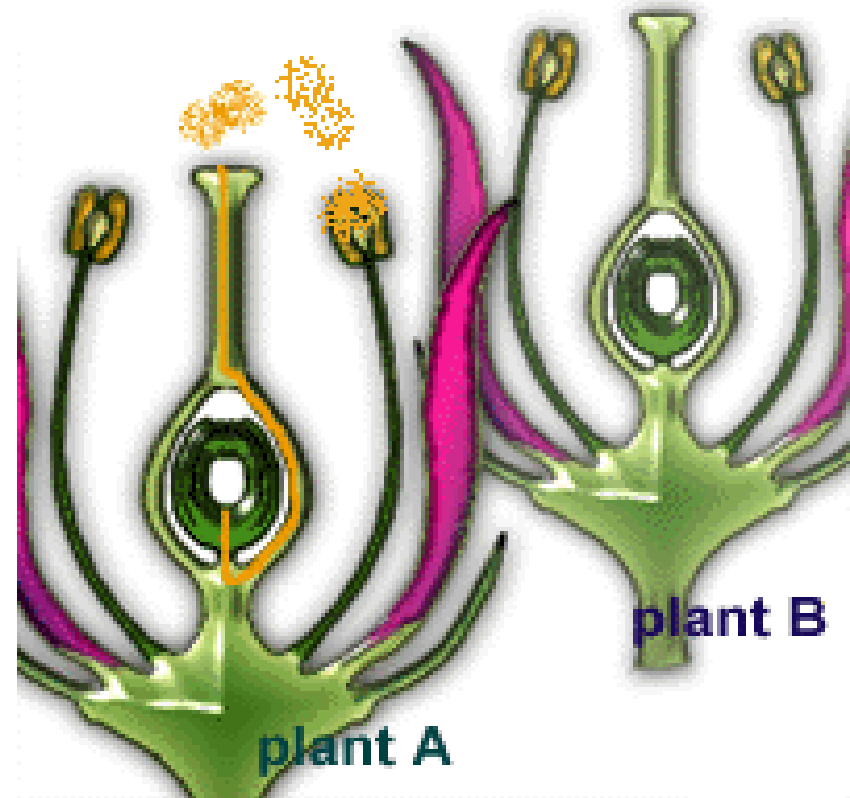

Advantages of Autogamy

- Insures seed set in absence of pollinators.
- Selectively advantageous by transmitting both sets of genes to offspring.
 - Well-adapted genotypes preserved.
- Only single colonizing individual needed.

Disadvantages of Autogamy

- Decreases genetic variability.
- Inability to adapt to changing conditions.
- Increases inbreeding depression.
 - Reduces heterozygosity and increases homozygosity of deleterious alleles.
 - More uniform populations.

then

Strategies to avoid self-pollination

Perfect flowers have both male and female organs, so plants have strategies to avoid self-pollination:

1. **Timing** - male and female structures mature at different times
2. **Morphological** - structure of male and female organs prevents self-pollination (imperfect flower)
3. **Biochemical** - chemical on surface of pollen and stigma/style that prevent pollen tube germination on the same flower (incompatible)

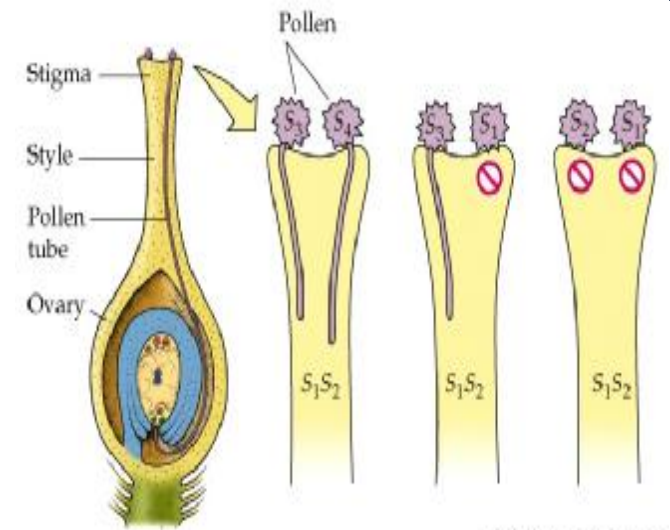

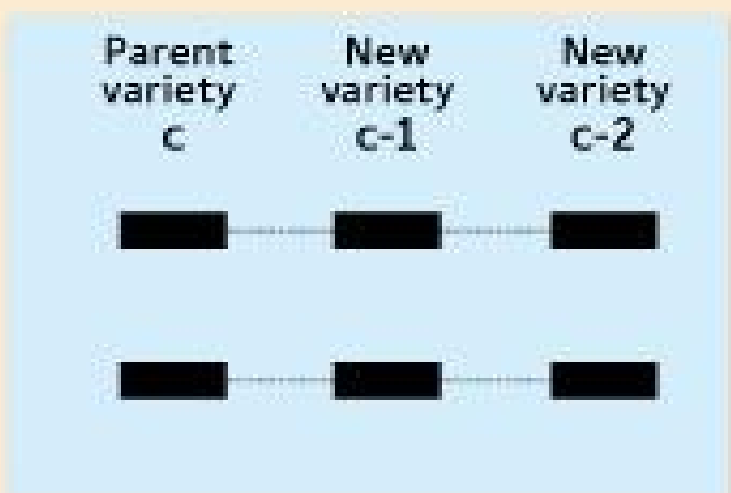
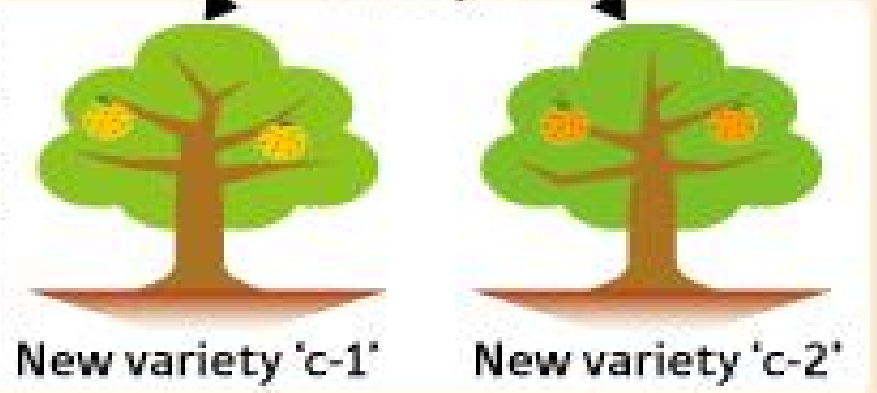
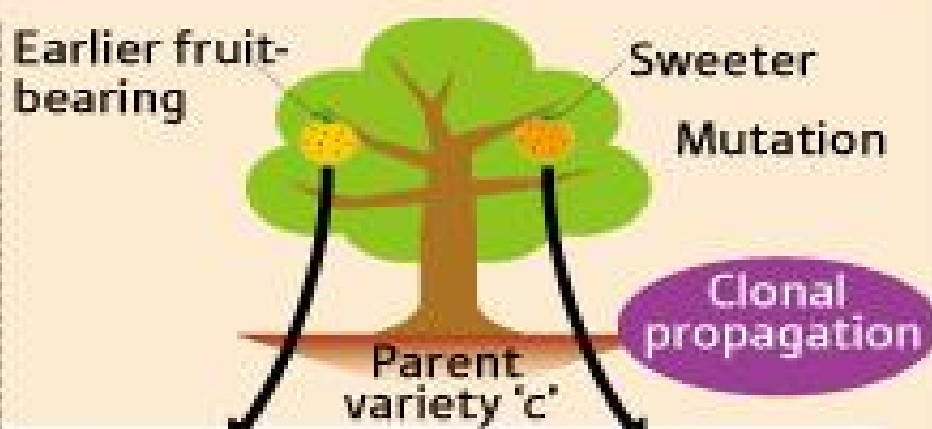
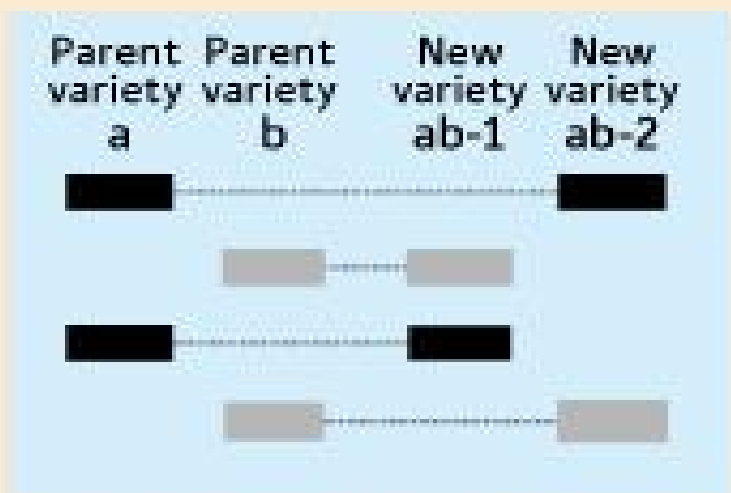
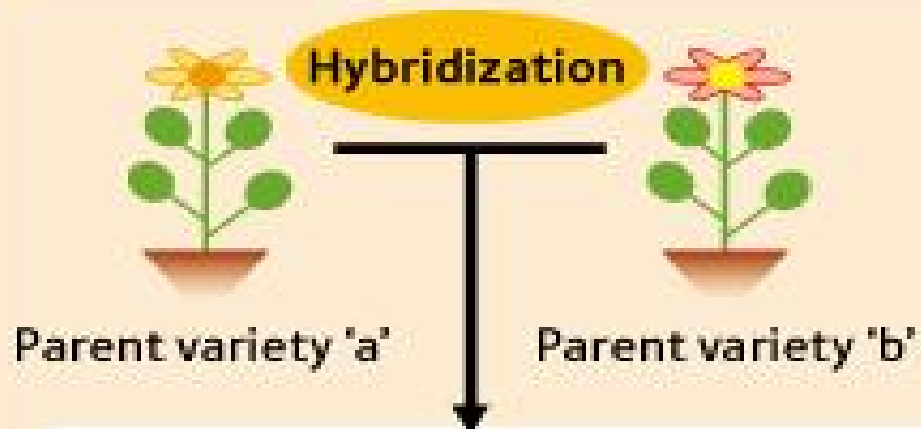

















- Male variety in flower



Cluster beginning to flower



Removal of the "cap" for emasculation



Emasculated flower cluster



Pollination with an entire cluster



Applying stored pollen with a brush



Japanese Plum Types, Plumcots, and Other Novel Interspecific Hybrids and Their Adaption to the Northeast

By

Jerome L. Frecon

Agricultural Agent and Professor 1, Rutgers New Jersey Agricultural Experiment Station,
Clayton, N.J. 08312

The Japanese-type plum varieties adapted to the milder temperate climates of the Northeastern US are of great diversity. Many of these plum varieties are the result of interspecific hybridization. Most plums described as Japanese are the result of crosses of the species *Prunus americana*, *Prunus salicina* and *Prunus simonii*. More recently *Prunus angustifolia* has been used by southern breeders to improve adaptability.

Generally, the Japanese type plum varieties grow on upright spreading, spreading to drooping trees and produce round to heart-shaped fruit (pronounced apex) with yellow to red, to almost black skin color.

Plumcots are interspecific hybrids of Japanese plums *Prunus salicina* and apricots *Prunus armeniaca*. Plumcot is a generic term for these hybrids

Pluots® are later-generations that show more plum than apricot characteristics; the fruit's exterior has smooth skin closely resembling that of a plum. Pluots were developed by [Floyd Zaiger](#), and "Pluot" is a registered trademark of [Zaiger Genetics](#).

Apriums® are complex plum-apricot hybrids that show more apricot traits. Genetically they are one-fourth plum and three-fourths apricot. Aprium varieties were developed in the late 1980s by [Floyd Zaiger](#), and "Aprium" is a registered trademark of [Zaiger's Genetics](#)



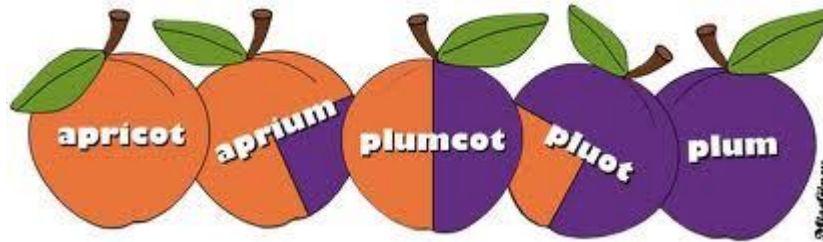
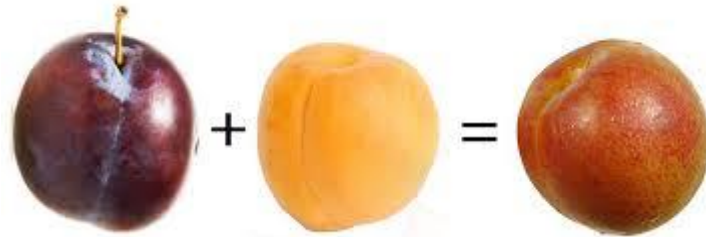

Crossability barriers

- ü the fusion of male and female gametes originating from individuals of different species/genera and/or the development of a fertilized ovule into viable seed
- ü Very frequent in interspecific and intergeneric hybridization program

Major interspecific crossability barriers

I.	Pre-fertilization barriers
	On the surface of the stigma before pollen tube entry
	Inside the tissues of the stigma and style
	Inside the ovary and embryo sac
II.	Post fertilization barriers
	Non viability of hybrid embryos
	Failure of hybrid to flower
	Hybrid sterility
	Hybrid breakdown in F2 or later generation

II. Post-fertilization barriers

- ü Result in the failure of fertilized ovules to develop into mature seeds
- ü More prevalent than pre-fertilization barriers
- ü May operate at different stages of embryo development or during germination and subsequent growth of the F1 hybrid

Factors:

- ü Unbalance of ploidy levels
- ü Abnormalities in the embryo development
- ü The presence of lethal genes
- ü Genic disharmony in the embryo
- ü Failure or early breakdown of endosperm (no cell walls are formed; short lived, disappearing before seed is mature)

II. Post-fertilization barriers

Techniques to overcome:

ü Removed of competing sinks

1. Crosses are made using the first flowers to open on the maternal parent
2. All immature fruits set on the maternal parent are removed before the cross is made
3. Remove all other fruit from the vicinity of a fruit produce by wide crossing
4. Pruning the maternal parent to remove all active growing point

ü Reciprocal crosses

ü Manipulation of ploidy level

ü Embryo rescue

ü Use of plant growth regulators

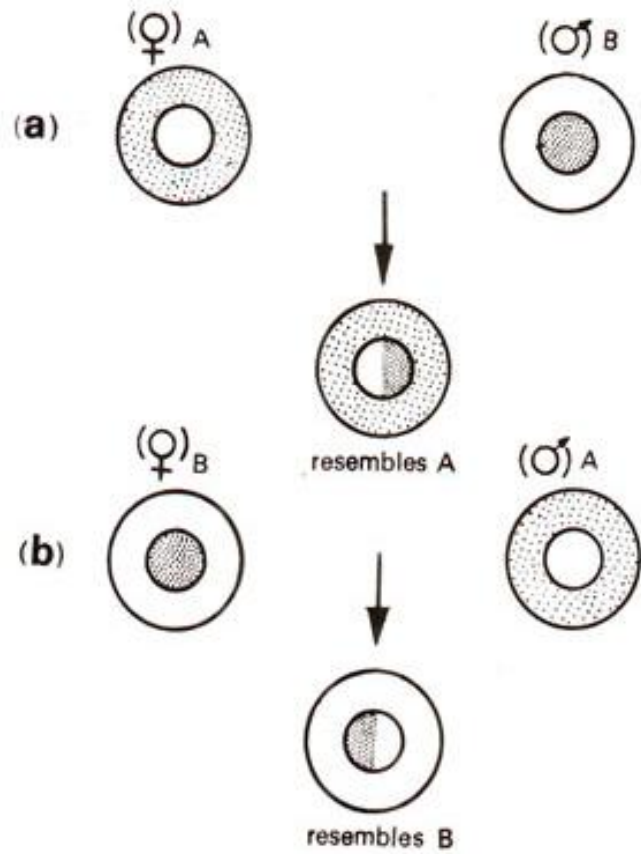

PRUNUS BESSEYI

August 17th, 2013

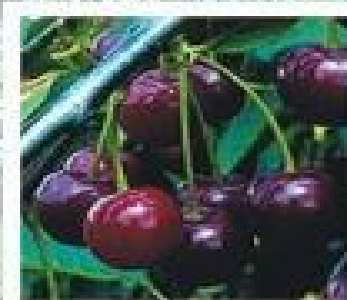

Beautiful, 4-6 foot shrubs or hedges with lovely white blossoms in spring then in summer each mature bush produces nearly 1/2 bushel of tempting, 1/2" purple-black glossy cherries for unforgettable pies, jams and jelly. Hardy and self-pollinating - it produces heavily even in poor soil. Plant 4 feet apart. Zones 4-9. 2-3 foot trees.

Protoplast Fusion

This is a non conventional genetic procedure involving fusion b.w isolated protoplast under in vitro condition and subsequent development of their product (heterokaryon) to a hybrid plant

Or

Development of hybrid plants through the fusion of somatic protoplasts of two different plant species/varieties is called somatic hybridization

Somatic hybridization technique

1. isolation of protoplast from suitable plants



2. Fusion of the protoplasts of desired species/varieties



3. Identification and Selection of somatic hybrid cells



4. Culture of the hybrid cells



5. Regeneration of hybrid plants

Isolation of Protoplast
(Separation of **protoplasts** from plant tissue)

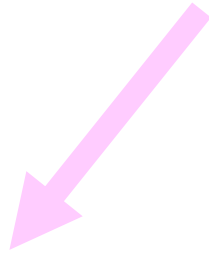

1. Mechanical Method

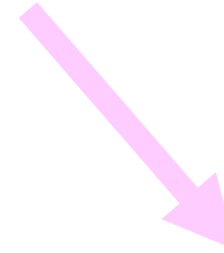

2. Enzymatic Method

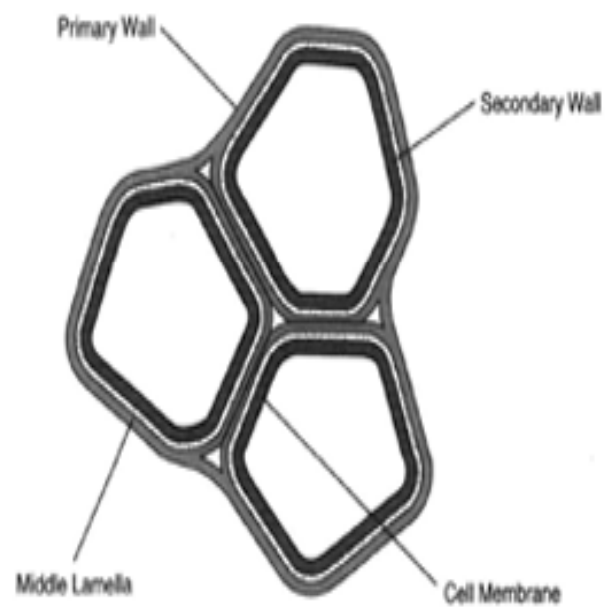
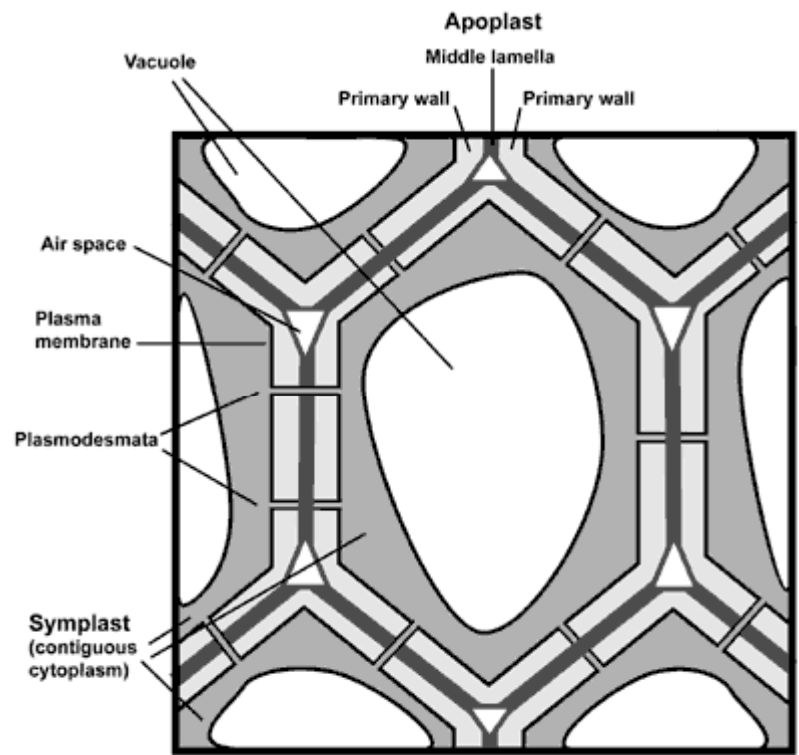

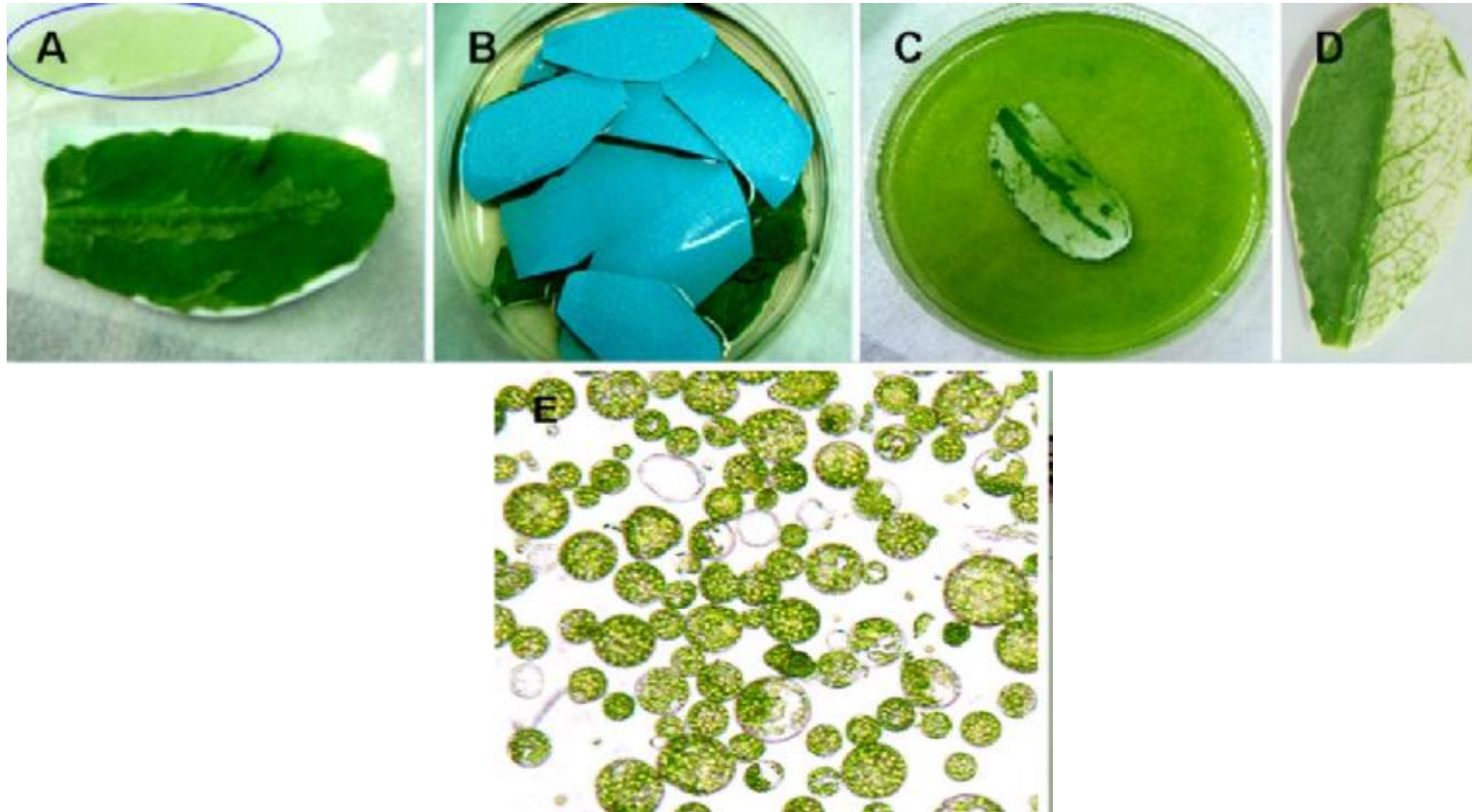

- (A) The upper epidermis was stuck onto Time tape and the lower epidermis was stuck to clear 3 M tape. The lower epidermal layer was removed by peeling away the 3 M tape; the blue circle indicates cells from the lower epidermis on the 3 M tape after peeling. (B) The leaves with Time tape still adhering to the top surface (with blue backing) were incubated in enzyme solution. (C) After 1 hr, the cell walls were digested and the protoplasts were released into the bottom of the dish. (D) The enzymes only digested the cell wall of those mesophyll cells that were not protected by lower epidermal cells. Left: intact; right: lower epidermal cells removed. (E) Protoplasts derived from mature *Arabidopsis* leaves

Spontaneous Fusion

- Protoplast fuse spontaneously during isolation process mainly due to physical contact

Induced Fusion

Types of fusogens

- PEG
- NaNO_3
- High pH/ Ca^{2+} ions
- Polyvinyl alcohol

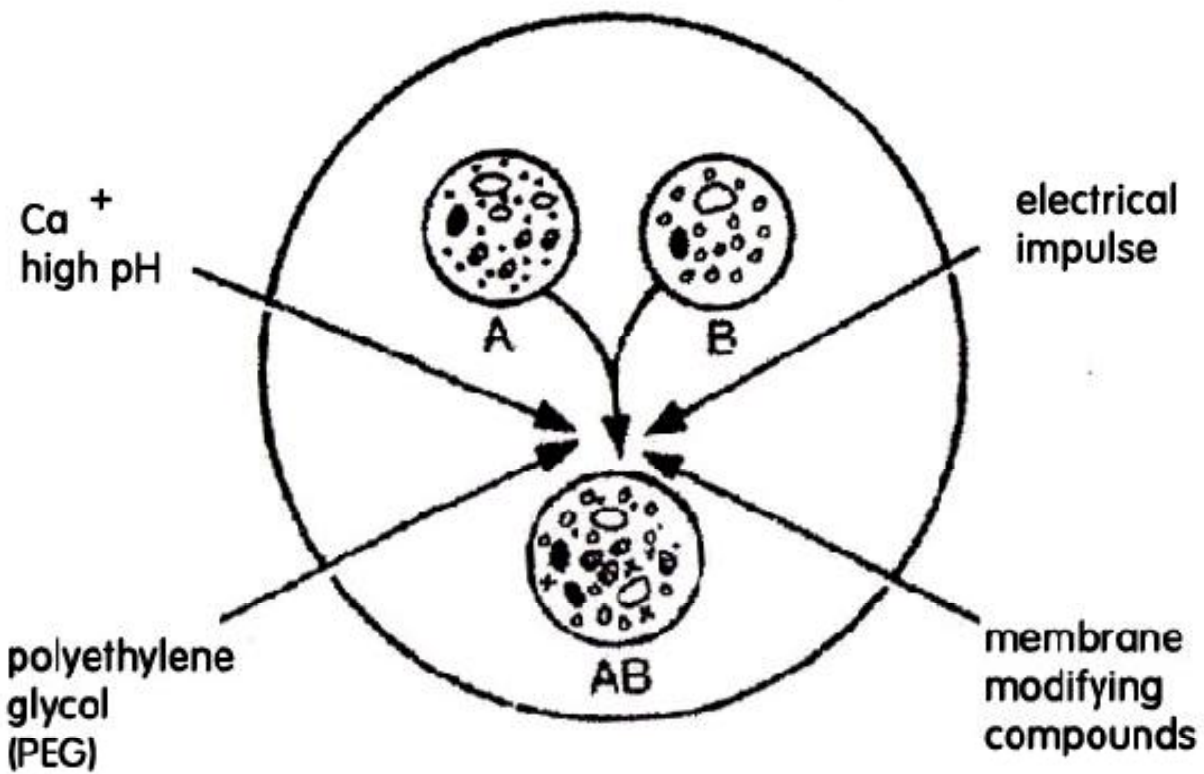



- Several chemical have been used to induced protoplast fusion. Sodium nitrate(NaNO_3) polyethylene glycol (PEG), calcium ion(Ca^{2+}), polyvinyl alcohol etc. The simplest and least expensive method to achieve protoplast fusion is by chemical method, of which the use of polymer polyethylene glycol (PEG) is the best known. The function of the PEG is the alter the membrane characteristic so that the protoplast become sticky and it the protoplasts are allowed to come into contact they will adhere together and the contents will fuse.

Advantages of somatic hybridization

- Production of novel interspecific and intergeneric hybrid
 - Pomato (Hybrid of potato and tomato)
- Production of fertile diploids and polyploids from sexually sterile haploids, triploids and aneuploids
- Transfer gene for disease resistance, abiotic stress resistance, herbicide resistance and many other quality characters
- Studies on the fate of plasma genes
- Production of unique hybrids of nucleus and cytoplasm

Limitations of Somatic hybridization

- Poor regeneration of hybrid plants
- Not successful in all plants.
- Production of unfavorable hybrids
- Lack of an efficient method for selection of hybrids

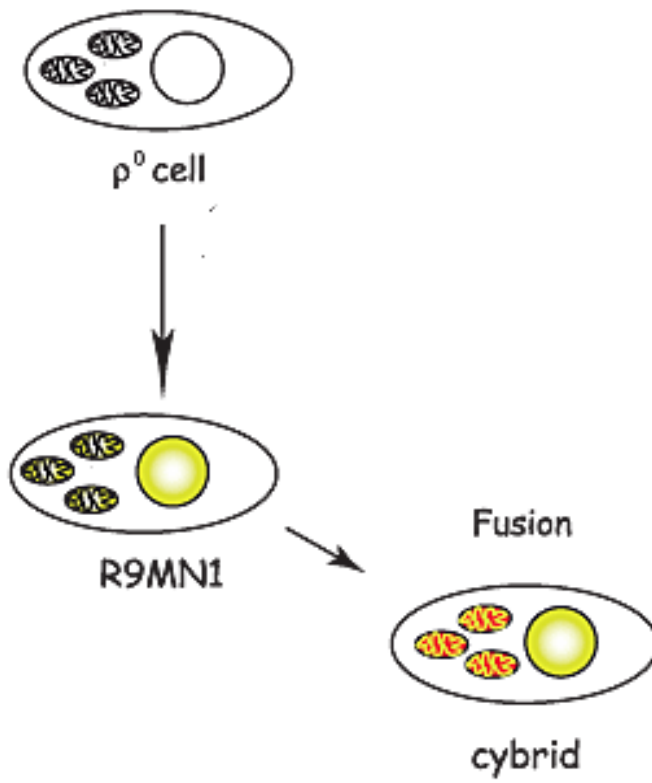

A new cultivar is created

- Step 1 - The Act of Breeding
- The host tree is the female. The pollen donor is the male
- Each parent is chosen on their desired traits
- Peach flowers are "emasculated" (the male parts are removed)
- Pollen is collected
- When the female pistil is receptive, pollen is introduced
- Fruit is harvested 80-120 days later
- Seed inside the pit is extracted and chilled for 120 days
- Seed germinates in a greenhouse
- seedling is planted in a field 1 year after breeding
- Seedling is assigned a temporary number
- In the 3rd season the seedling bears fruit and evaluation begins



Step 2 - Evaluation

Tree Characteristics:

Growth in the previous year

Extent of winter injury

Extent of "peach canker" disease

Amount of bloom on the tree

The Fruit:

Size, firmness, freeness from the pit

Fruit colour, lush, background colour

Eating quality

Red pigment in the flesh

Split pits

Resistance to disease

Overall rating



The Peach Crop:

Amount of crop on the tree

Uniformity of the crop

Ripening date



- Step 3 - Preparing for Introduction
- The cultivar goes for virus certification
- Amass a supply of propagation material
- Name the peach
- What's in a Peach Name?
- "V790632" =
- V identifies that it came from Vineland
- 79 identifies the year (1979) of the cross
- 06 is the combination of parents
- 32 means it is the 32nd selection of that cross
- V790632 was named "**Vulcan**" in 1994





- Although **Fuji** originates from Japan, its parentage is all-American, a cross between **Red Delicious** and **Ralls Janet**. In terms of shape and skin texture it looks like Ralls Janet - but with the strong red coloration of Red Delicious overlaid to produce a lovely pink hue



- In 1935, **Idared** was crossbred between the **Jonathan** and **Wagener** Apples in Idaho, USA.

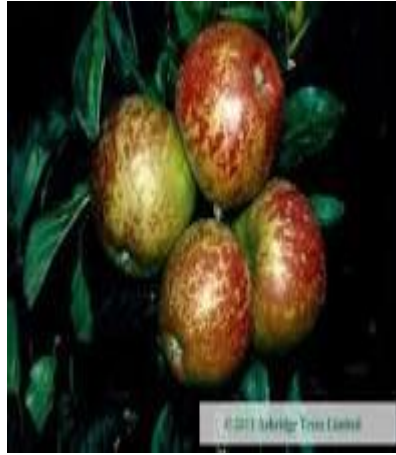

Gala was crossbred between the **Golden delicious** and **kidd's orange red**



Jonagold was crossbred between the **Golden delicious** and **Jonathan**

University of Florida researchers have introduced the new fruit, which ripens early, produces high yields, and is disease-resistant. The black fruit features exceptional taste and texture with an edible skin, making it well suited for fresh fruit consumption and the potential for wine production.

The name "Delicious" was selected based on the comments of vineyard visitors who sampled the fruit.

According to Dr. Dennis J. Gray, who led the research study published in the February 2009 issue of HortScience, "Delicious" (*Vitis rotundifolia* Michx.) originated from a cross between AA10-40, a self-fertile, bronze-fruited selection with medium-sized berries, and CD8-81, a self-fertile, black-fruited selection with larger berries.



Mutation Breeding

Historical Account



Hugo de Vries

- *Hugo de Vries: 1900. introduced the term “Mutation”.*
- *Mutants were observed before this: e.g., short legged sheep was discovered by an **English Farmer** in **18th century**. This sheep was used to develop a breed-c/a **Ancon**.*
- *Muller-discovered the action of X-rays on *Drosophilla* and **Stadler** discovered the effect of gamma-rays in barley.*
- *Mutation Breeding Programme was started in Sweeden, USSR and Germany in 1927 after the discovery by Muller.*



Short-legged sheep

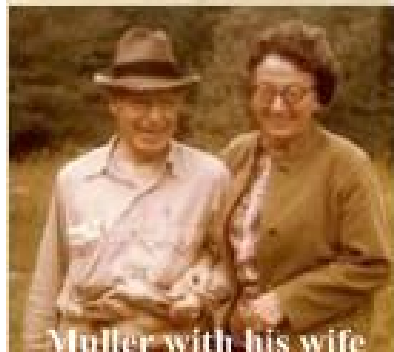

Muller with his wife



Stadler

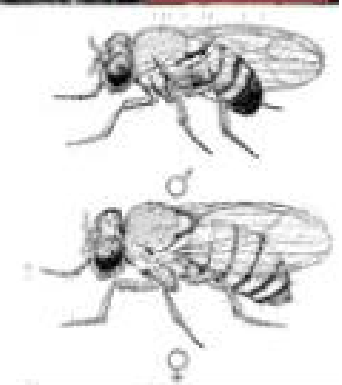

Mutation - Mutant

- Mutation

Changes in genes and chromosomes

- Mutated

Altered genes

- Mutant

New organism with a mutated gene or rearranged chromosomes

Mutation breeding is successful when.....

- ✦ Desired variability exhausts in cultivated species and germplasm.
- ✦ When a desirable variety has an oligogenic genetic defect.
- ✦ There is tight linkage between desirable and undesirable traits.
- ✦ Only one or two characters are to be improved in a fruit crop without changing its taste.
- ✦ Crop does not have sexuality, thus lacks variability.
- ✦ The generation cycle is very long, such as plantation crops, fruit trees....there mutation breeding is the shortcut way for genetic improvement.
- ✦ In ornamental plants



Mutant Dog Rose Flower



Mutant yellow Rose



Red Rose

Application of mutation breeding

- ✦ Induction of desirable mutant alleles which may not be present in the germplasm available to the breeder.
- ✦ In improving specific characteristics of well adapted high yielding variety .
- ✦ Mutagenesis has been successfully used to improve various quantitative characters including yield.
- * Can apply selection to single cells

Limitations

- ✦ The frequency of desirable mutants is very low.
 - ✦ Desirable mutations are commonly associated with undesirable side effects.
 - ✦ There may be problems in the registrations of a mutant variety.
 - ✦ Mutations in quantitative traits are usually in the direction away from the selection history of the parent variety.
 - ✦ Most of the mutations are recessive.
- * Many mutations are non-heritable

Effects Of Mutation

★ **Lethal** :- They kill each & every individual that carry them in appropriate genotype .

Dominant lethal : It can't survive.

Recessive lethal : kill in homozygous state.

Sub Lethal & Sub Vital :- Both mutation reduce viability but don't kill all the individual carrying them in appropriate genotype.

Sub Lethal : Kill more than 50%.

Sub Vital : Kill less than 50%.

Vital :-

a) Don't reduce the viability.

b) Crop improvement can utilize only such mutations.

**Lethal , Sub lethal
mutations have no value
in crop improvement.**

Genetic structure changes

q Gene (point mutation)

q Chromosome

q Genome

Gene (point) mutation

- a change in specific sequence of nucleotides in DNA molecules leading to the formation of a new type of protein or preventing that of the normally protein
- take place at the molecular or sub-microscopic level
- Such change may be accompanied by the emergence of a new trait inherited in accordance with Mendel's Laws

Point Mutation

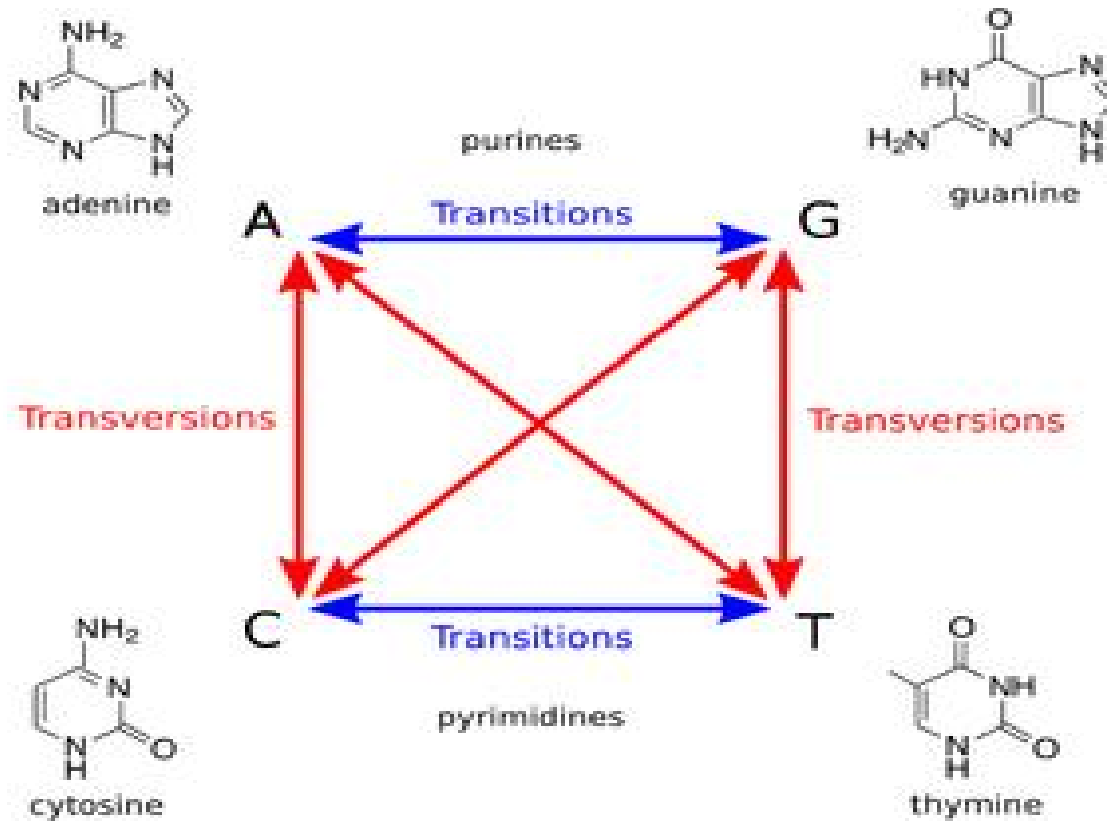

	U	C	A	G
U	UUU = phe UUC = phe UUA = leu UUG = leu	UCU = ser UCC = ser UCA = ser UCG = ser	UAU = tyr UAC = tyr UAA = stop UAG = stop	UGU = cys UGC = cys UGA = stop UGG = trp
C	CUU = leu CUC = leu CUA = leu CUG = leu	CCU = pro CCC = pro CCA = pro CCG = pro	CAU = his CAC = his CAA = gln CAG = gln	CGU = arg CGC = arg CGA = arg CGG = arg
A	AUU = ile AUC = ile AUA = ile AUG = met	ACU = thr ACC = thr ACA = thr ACG = thr	AAU = asn AAC = asn AAA = lys AAG = lys	AGU = ser AGC = ser AGA = arg AGG = arg
G	GUU = val GUC = val GUA = val GUG = val	GCU = ala GCC = ala GCA = ala GCG = ala	GAU = asp GAC = asp GAA = glu GAG = glu	GGU = gly GGC = gly GGA = gly GGG = gly

No mutation

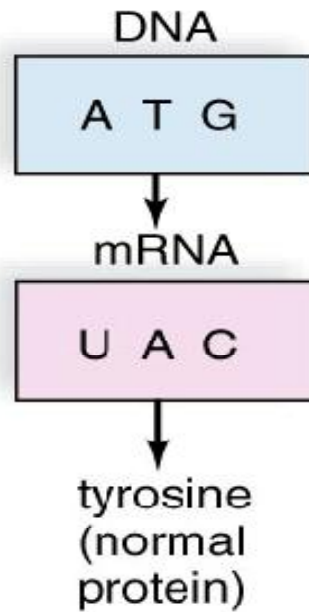

Point mutations

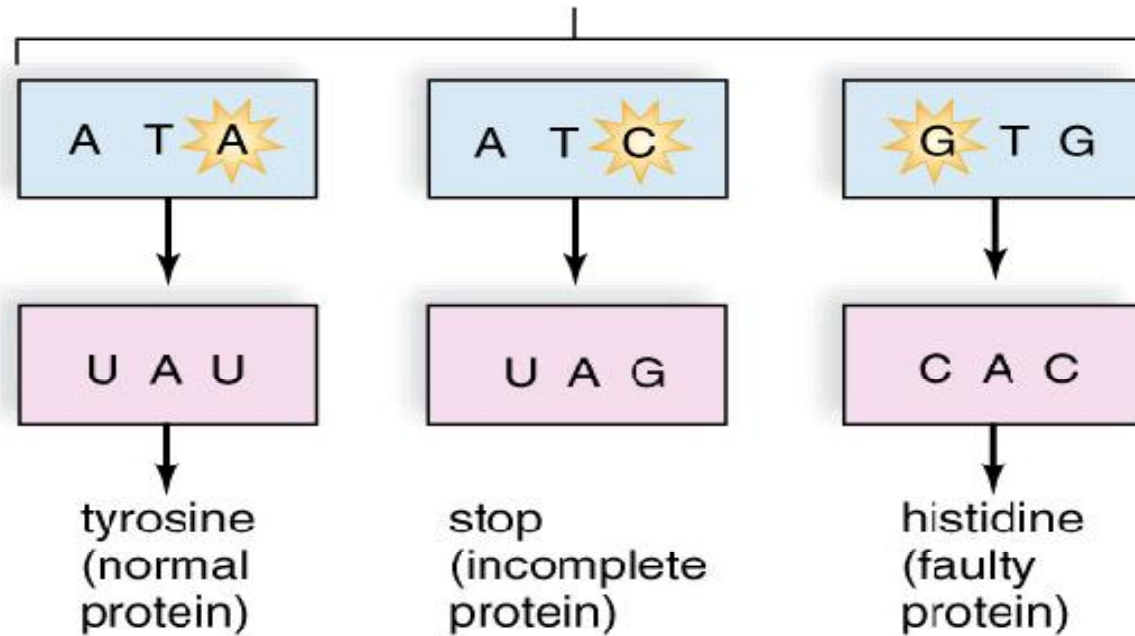

Silent M.

Non Sense M.

Missense M.

Point Mutations

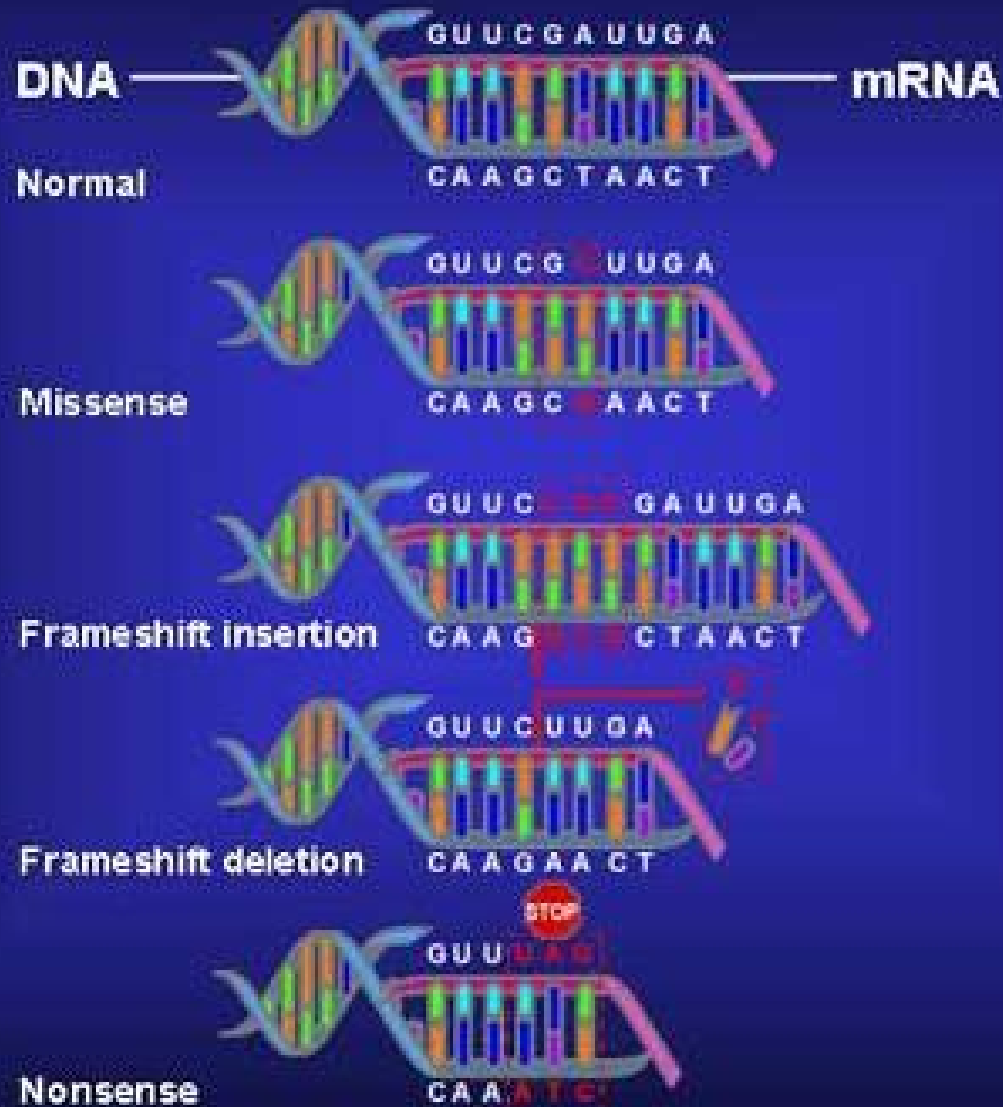

Chromosomal mutation

- q Mutation associated with splitting and subsequent changes in the structure of the chromosomes
- q The end of the split chromosomes may fuse to form structure again, but the new chromosomes are not always exactly what they used to be
- q The microscopic structures of chromosomes may be characterized by **deletion** or **deficiency** (loss of a chromosomal segment), **duplication** (doubling of a chromosomal segment), **inversion** (rearrangement of a group of genes in a chromosomal segment in a such a way that their order is reversed; rearrangement of genetic material in a chromosome results from loss of segment, its rotation by 180°, and fusion of the separated ends) and **translocation** (change in a position of a chromosome or more often exchange of segments between different chromosomes)

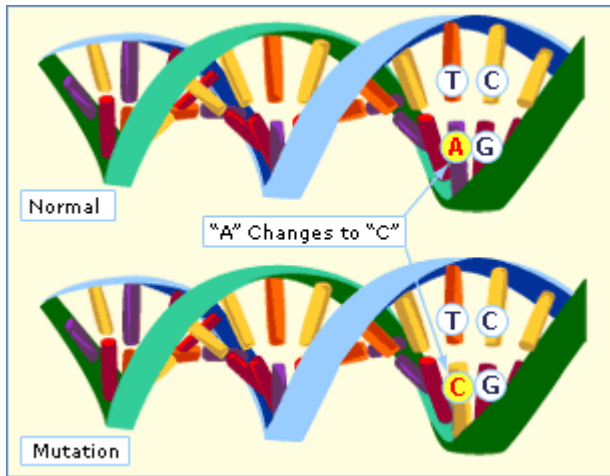

Point Mutation

This is a single change in one of the four nucleotide bases. An "A" might change to a "C" for example.

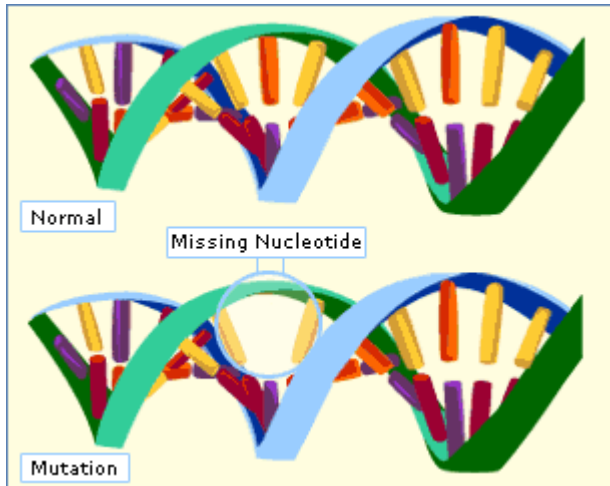

Deletion

Part of the DNA sequence is missing.

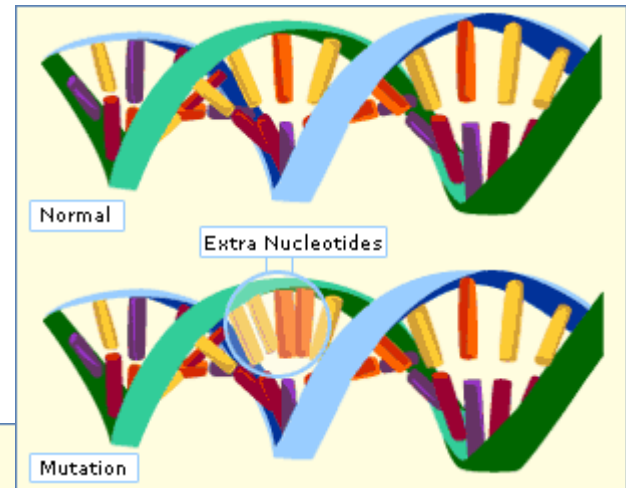
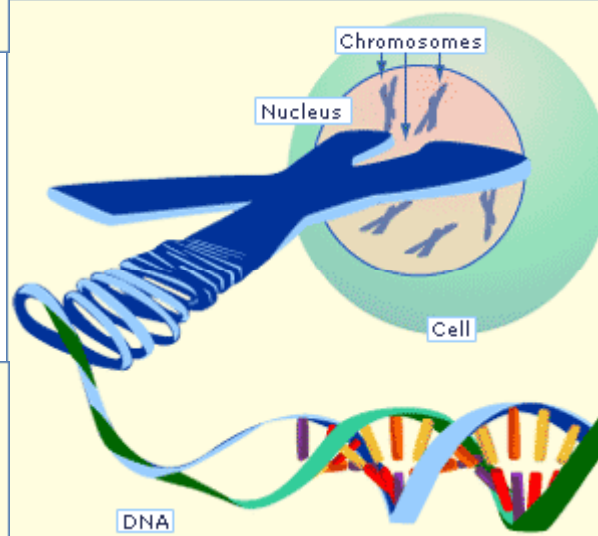

Insertion

Extra nucleotides are added to the sequence.

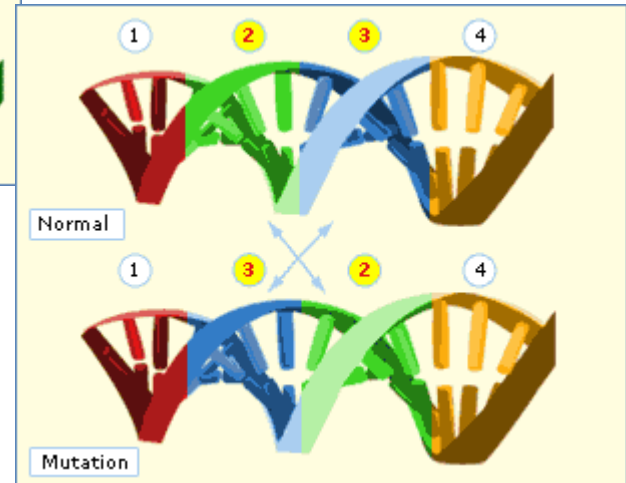

Inversion

A portion of the DNA sequence is reversed.



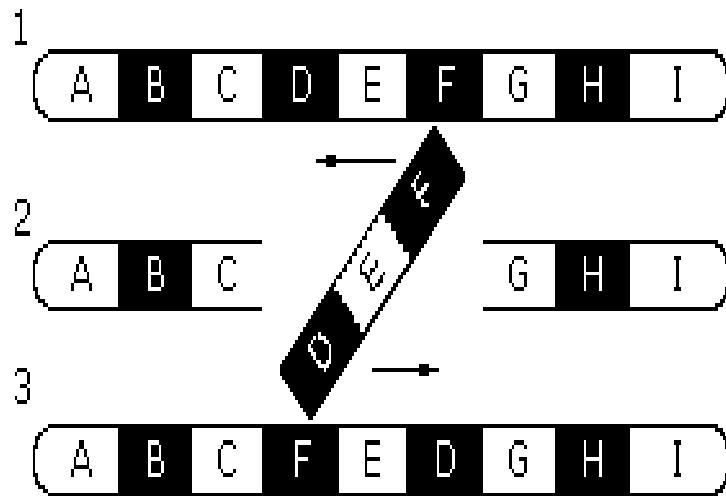

Inversion

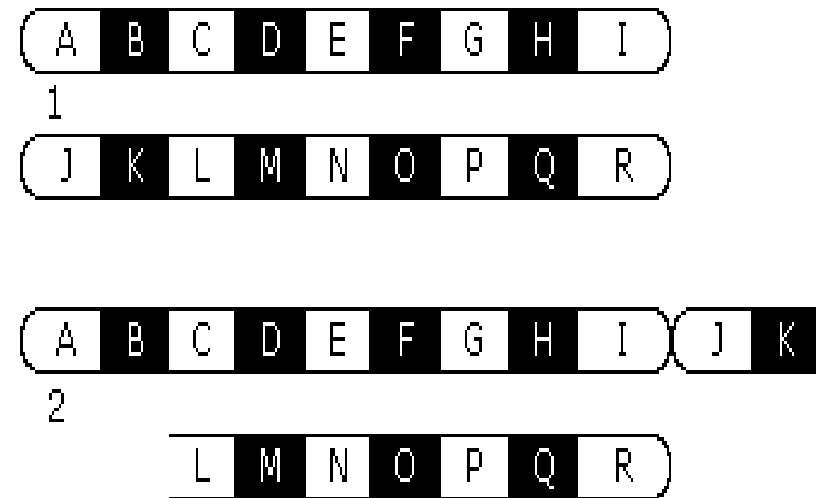

Translocation

Genome mutation

q Changes in sets of chromosomes

Remarks:

1. Breeders are more interested in gene mutation, because chromosomal rearrangement usually produce negative results, such as lower fertility of the offspring
2. Mutant are often of great value for breeding as sources of new, previously unknown useful characters
3. Mutagenesis may be instrumental in obviating the technical difficulties arising in the crossing of such a small flowered crops such as milled

Phenotype

Wild-type

Mutant

Wild-type

Genotype

+

Mutation

m

Back-mutation

Suppressor mutation

Phenotypic reversion

+

m

s

(1)

(2)

Backcross to wild-type:

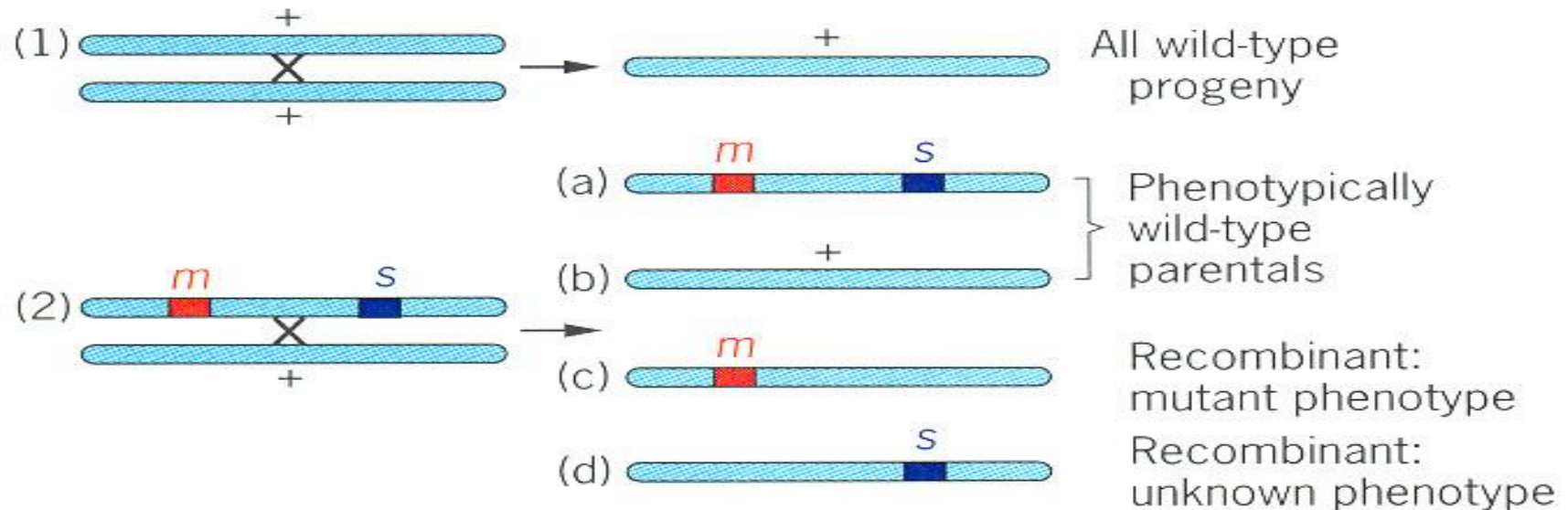

Type of mutation

q Spontaneous (natural) mutation

1. Some have played an outstanding role in development of valuable crop cultivars and hybrids
2. Unfortunately, it can not form the basis of modern plant breeding due to its low frequency and difficulties in detection

q Induced mutation

Technique for inducing mutation

- ü Physical mutagens
- ü Chemical mutagens

Physical mutagens

1. Various sources of ionizing radiations are explored, most often X and gamma rays, UV radiation, fast and slow neutron, alpha ray, beta ray
2. Radioactive isotopes P-32 and S-35 are not convenient for use due to the storage and application difficulties
3. The usual sources of gamma rays in laboratories are radioactive cobalt (Co-60) and Cesium (Cs-137) placed in cobalt bomb

Physical mutagens

4. The object can be irradiated in two ways:
 - ü With an aid of a powerful source of a short-duration gamma rays for short duration radiation. Need special units for irradiating living object
 - ü A much weaker radiation but operating continuously (gamma field).
5. the dosage must be varied depending not only on the plant species whose seeds/organs are irradiated, but also on many other factors
6. plant must be irradiated heavily enough to ensure as many inherited changes as possible but without seriously affecting the germination, growth and fertility of plant directly emerging from the irradiated seeds or vegetative organs (*critical radiation dose*: dosage which strong enough to assure many mutation not yet so strong as to kill plants)

Chemical mutagens

- ü Mutagenic substances belonging to different classes of chemical compounds, such as ethylene imine, diethyl sulfate, dimethyl sulfate, N-nitrosoethyl urea, N-nitrosomethyl urea, methal sulfonate, diepoxy butane, ethyleneoxide
- ü Most are highly toxic, usually result in point mutations
- ü Use in solution in the concentration ranging from tenth – hundredths even thousandths of percent
- ü Many chemical mutagens are much more effective than physical one. If irradiation of crops produces 10 – 15% of viable inherited changes, chemical mutants do the same at a rate of 30 to 60%
- ü They often exert more specific and finely tuned action on the cell

Chemical mutagens

- ü Some substances (supermutagen) are capable of causing inherited changes in plants at a rate up to 100%
- ü Chemical mutagens aim at the most vulnerable spot of a living organism (DNA) to induce changes in nucleotides and alter the genetic information (Sometimes causes specific mutation)
- ü It provides a powerful tool to induce desired changes in a trait

Part of the plant to be treated



Seeds, pollen grains, buds/cuttings or complete plant can be used for mutagenesis.

It depends on whether the crop is sexually or asexually propagated & type of mutagen to be used.



Sexually propagated crops :



Seeds are commonly used because seed can tolerate extreme environmental conditions.



Use of mutations in **sexually** reproduced crops

- ü More valuable in self than cross pollinated.
The probability of producing desirable mutations and genetic variability is theoretically higher
- Ø Seeds
- Ø Very young seedling

✚ Pollen grains are also infrequently used because :-

- i. They are difficult to collect in large quantities .
- ii. Hand pollination(with treated pollens) is rather difficult.
- iii. Survival percentage of pollens is relatively low.

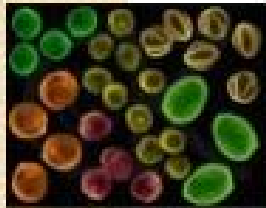

Note:- Pollen grains are the only plant part which can be treated with ultra violet rays.

Clonal crops : Buds/cuttings are used for mutagenesis.

Use of mutations in **asexually** produced crops

- ü It has been much easier and quicker to obtain variant plant types
- ü Specific location of the mutation event (segmental chimera) becomes important.
- ü The mutant must be in meristematic tissue that will produce faithfully through cutting or other vegetative means

- Ø Bud
- Ø Scion
- Ø Cutting
- Ø Tuber
- Ø bulbs

Dose and duration of the mutagen

- ✦ The usefulness of a mutagen and its efficiency depends on the mutagenic agent employed as well as on specific characteristics of the biological system to be treated.
- ✦ An optimum dose is the one which produce the maximum frequency of mutation and causes minimum killing.

LD₅₀ dose should be optimum.



Description of generations

- ✦ **M1** Plants obtained from treated seeds/cuttings or from seeds obtained after pollination with treated pollens are called M1 plants

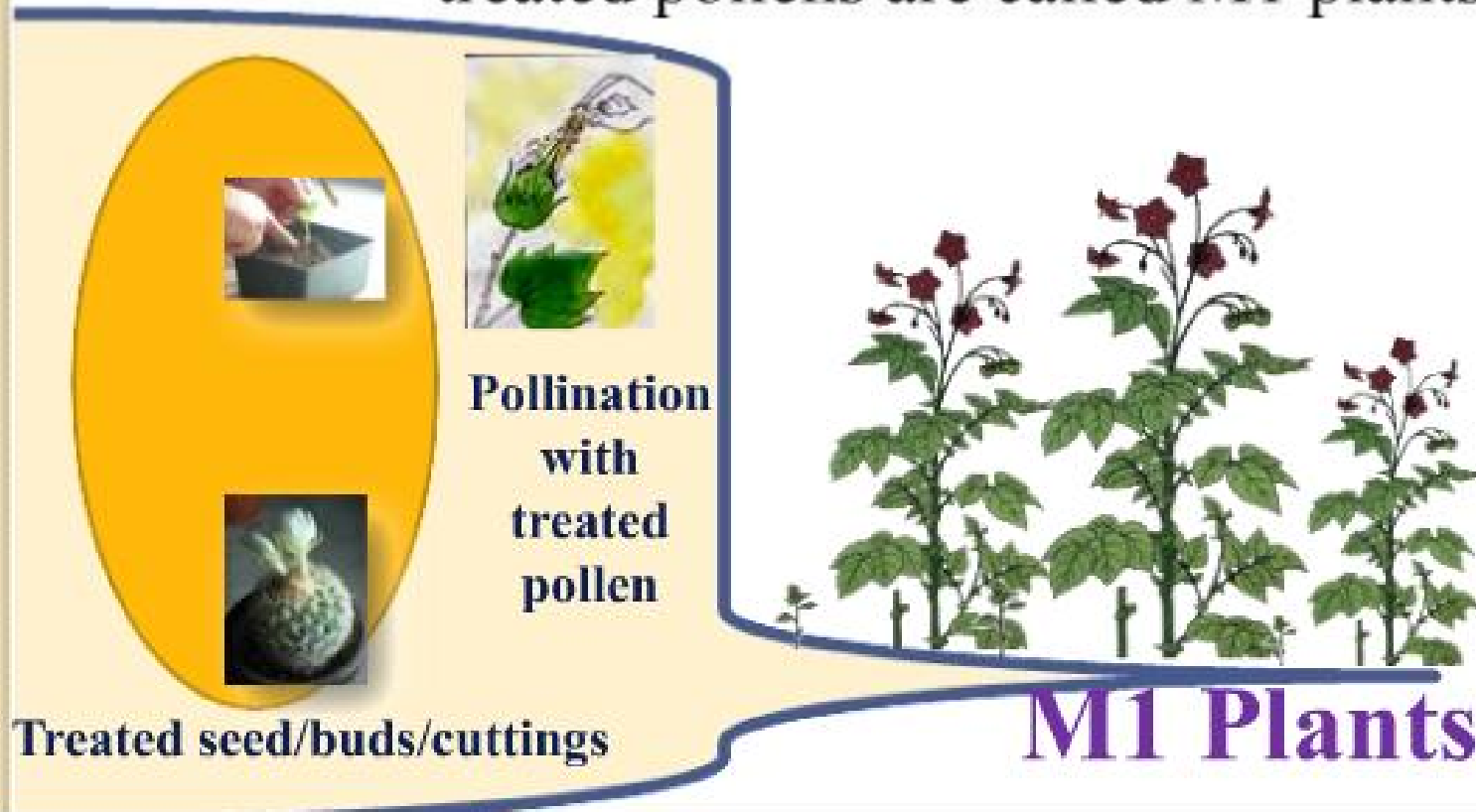

Mutation breeding scheme for **seed** propagated crop

- ü Mutagenic application
- ü Growing the plants (M1 generation)
- ü Identification of induced mutation, seed harvest from mutated plants (M2)
- ü Continue the identification and selection of induced mutation (M3)
- ü First agronomic evaluation. Propagation of promising lines (M4)
- ü Multilocation trials of stable mutant and recombinant lines (M5 – M8)
- ü Official testing and releasing of mutant (M9)

Description of generations

- ✦ **M1** Plants obtained from treated seeds/cuttings or from seeds obtained after pollination with treated pollens are called M1 plants



M1 Plants

- Large no. of plants are grown
- Grown in wider spacing.
- Dominant mutations are recorded if any (generally mutations are recessive and do not express in M1)
- Chlorophyll sectors and fertility is recorded.
- M1 plants are selfed and their seed is harvested separately.

Mutation breeding scheme for **vegetative** propagated crop

- ü Mutagenic application
- ü Cutting back the M1V1 shoot, bud grafting, or in vitro propagation via axillary buds
- ü Isolation of induced somatic mutation, establishment of clones, cutting back of non-mutant shoots from chimeric plants (M1V2)
- ü Further isolation of somatic mutations, vegetative propagation of mutant plant (in vivo or in vitro), preliminary evaluation of mutants (M1V3)
- ü Evaluation of mutant clone performance, assessing segregation from mutant crosses and reselection of desired recombinants. Released of improved mutant (M2V4)

Procedure for Vegetative propagated crops



- In Veg. Prop. Crops mutations are expressed in the form of chimeras.
- The chimera refers to genetically different tissue in an individual. The individual has one type of tissue in one part and another type of tissue in another part.



Procedure for Vegetative propagated crops

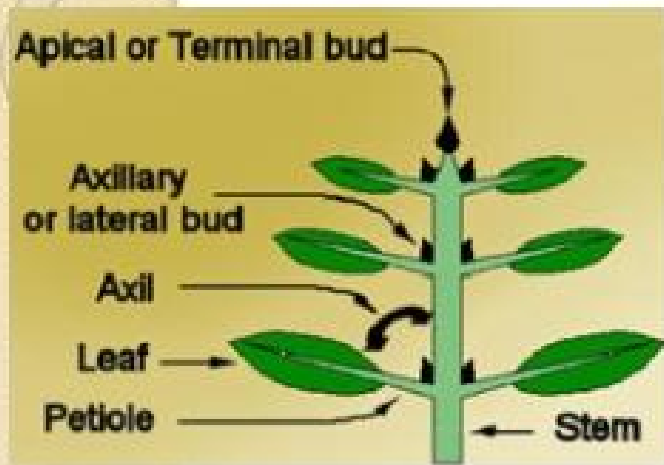

❖ In apical buds, axillary buds and adventitious buds, there are two functional layers, outer layer and inner layer. When the changes occur in entire inner or outer layer, it is also known as *Periclinal Chimera* and when only a part of inner or outer layer is altered, it is called *Sectorial Chimera*.

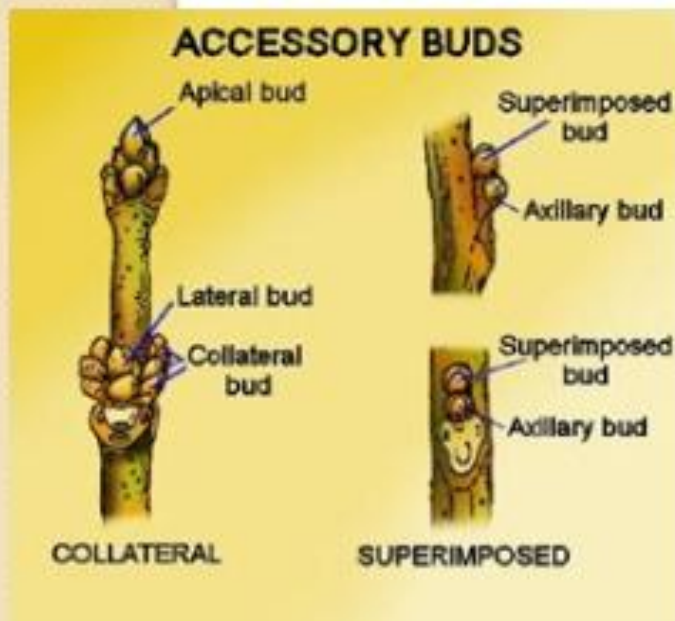

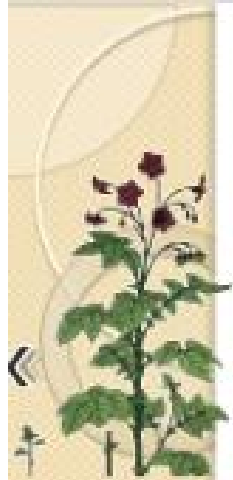

Chimera ?

- Vegetative mutations are expressed in the form of chimeras.
- Periclinal chimera (whole of inner and outer layer)
- Sectorial chimera(part of inner/outer layer)
- Seed propagated crop-inner layer important...seed formation

Chimera - a plant or plant part composed of genetically different layers



Chimera?

Three functional layers

- L1: Produces Epidermis
- L2: Produces leaf mesophyll and gametes.
- L3: Produces rest of plant body

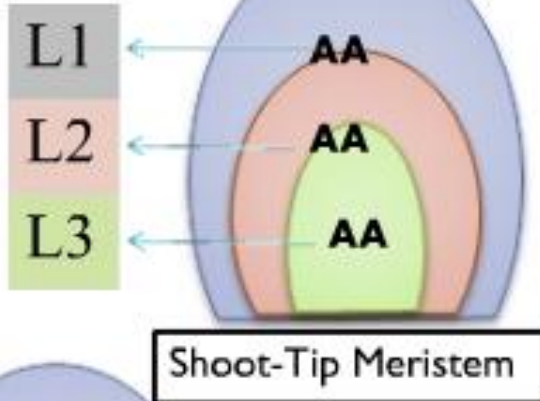

Sectorial and Periclinal Chimeras produced by mutagenesis. The Mutant allele (a) is recessive.

When part/segment of the L1, L2 or L3 is affected, it is called **SECTORIAL CHIMERA**

When whole of the L1, L2 or L3 is affected, it is called **PERICLINAL CHIMERA**

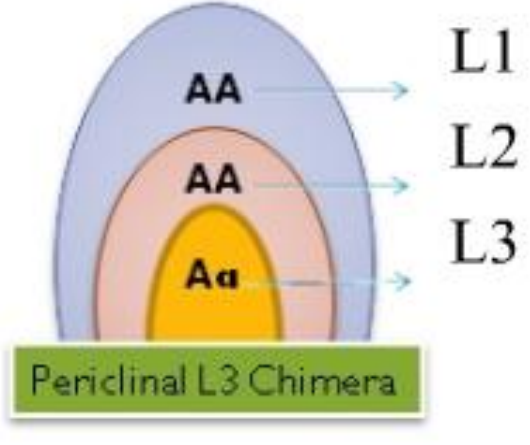
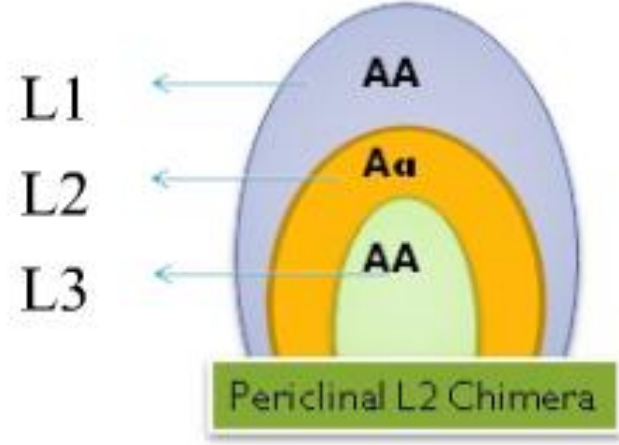
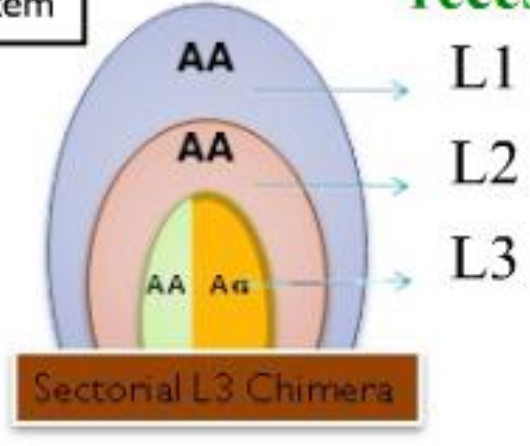
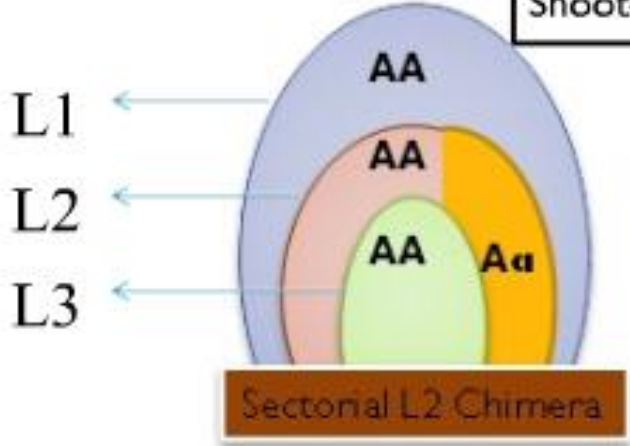

Types of Chimeras

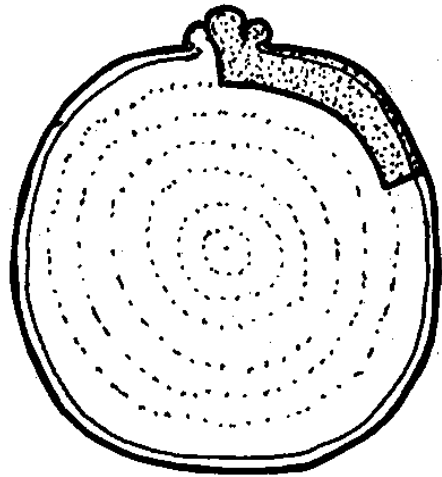

Mericlinal

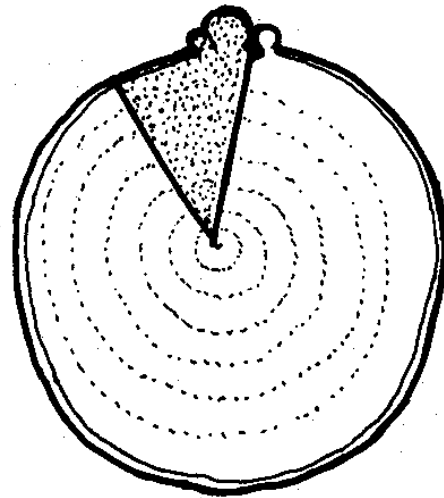

Sectorial

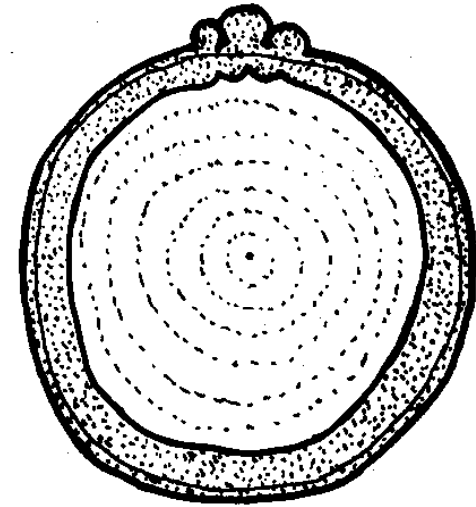

Periclinal

Chimera?

Chimera - a plant or plant part composed of genetically different layers

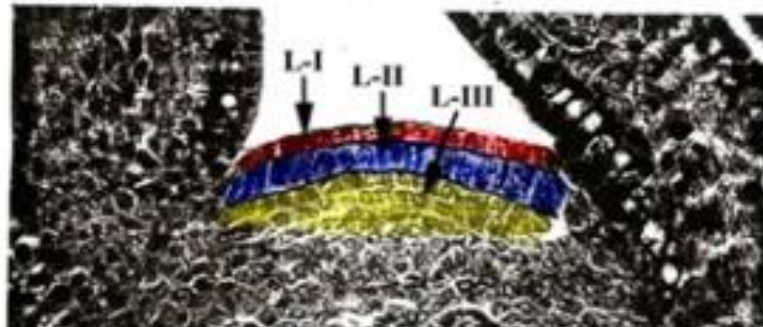
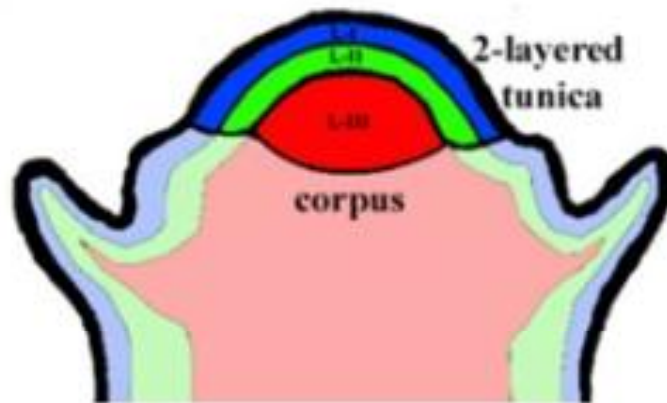

The most common example is a "variegated" plant where different regions of the leaf are yellow or white due to the lack of chlorophyll synthesis, i.e. these are **chlorophyll mutants**.

However, there are many kinds of chimeras.

Thornless blackberries are chimeras where the L-I epidermis lacks the ability to produce thorns. Some fruits have sweet and sour regions of flesh, which may be a chimera.

Alöe mitriformis variegata



Variegated Geranium



Acer platanoides

"Drummondii" (Family: Aceraceae)
Common name: Variegated Norway
maple

Chimeras



Albino peach shoot



Partial reversion of
Red Delicious

**Sectorial
chimera
(mutation)**





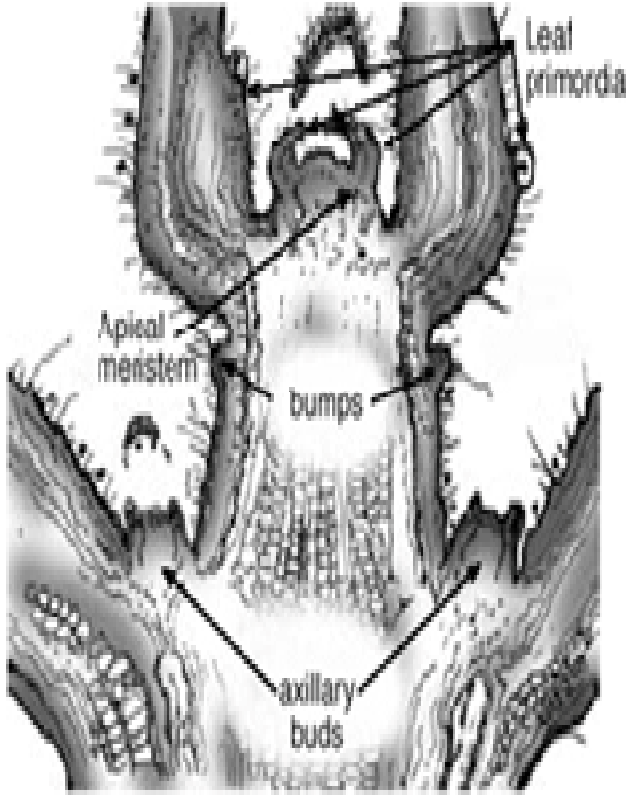
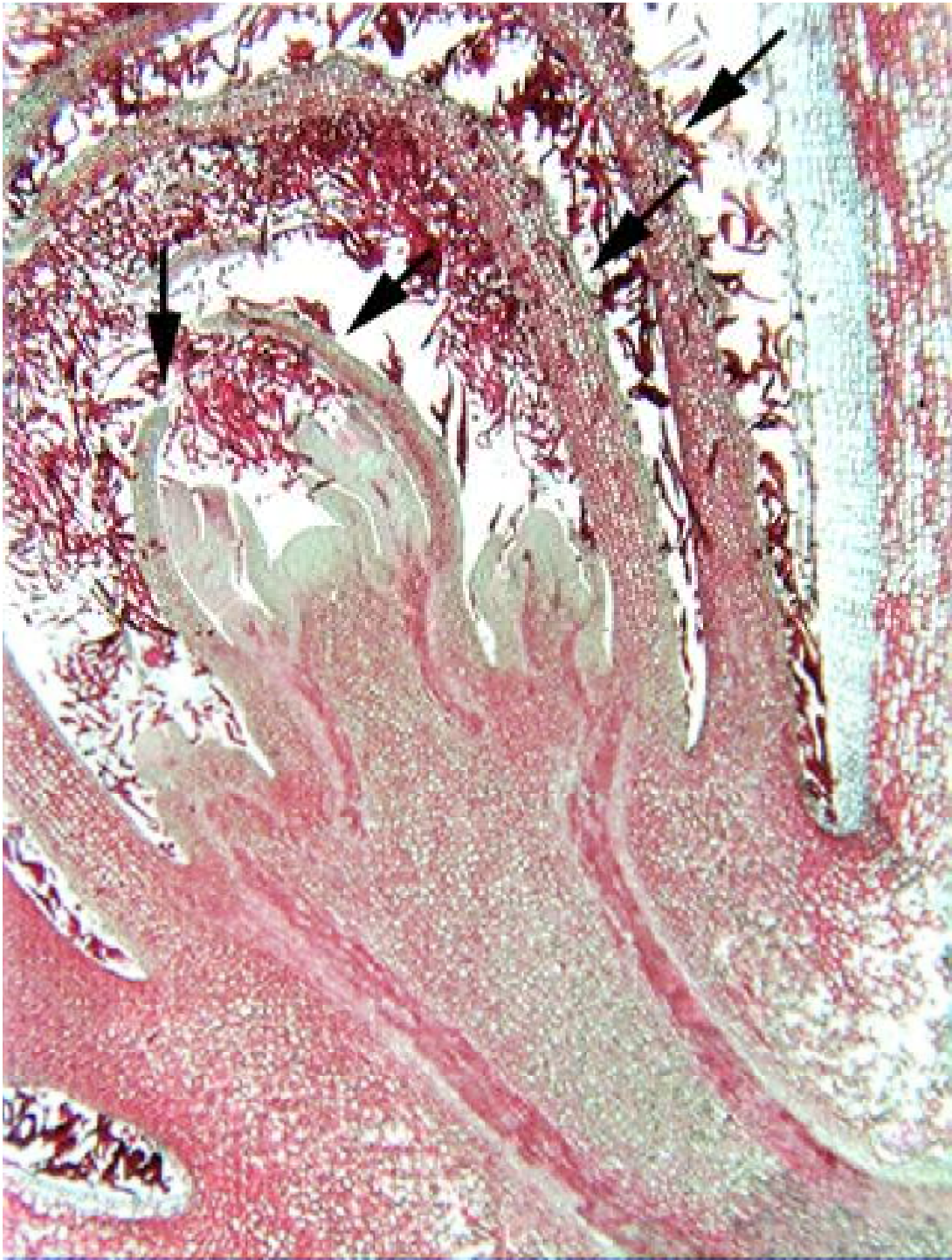

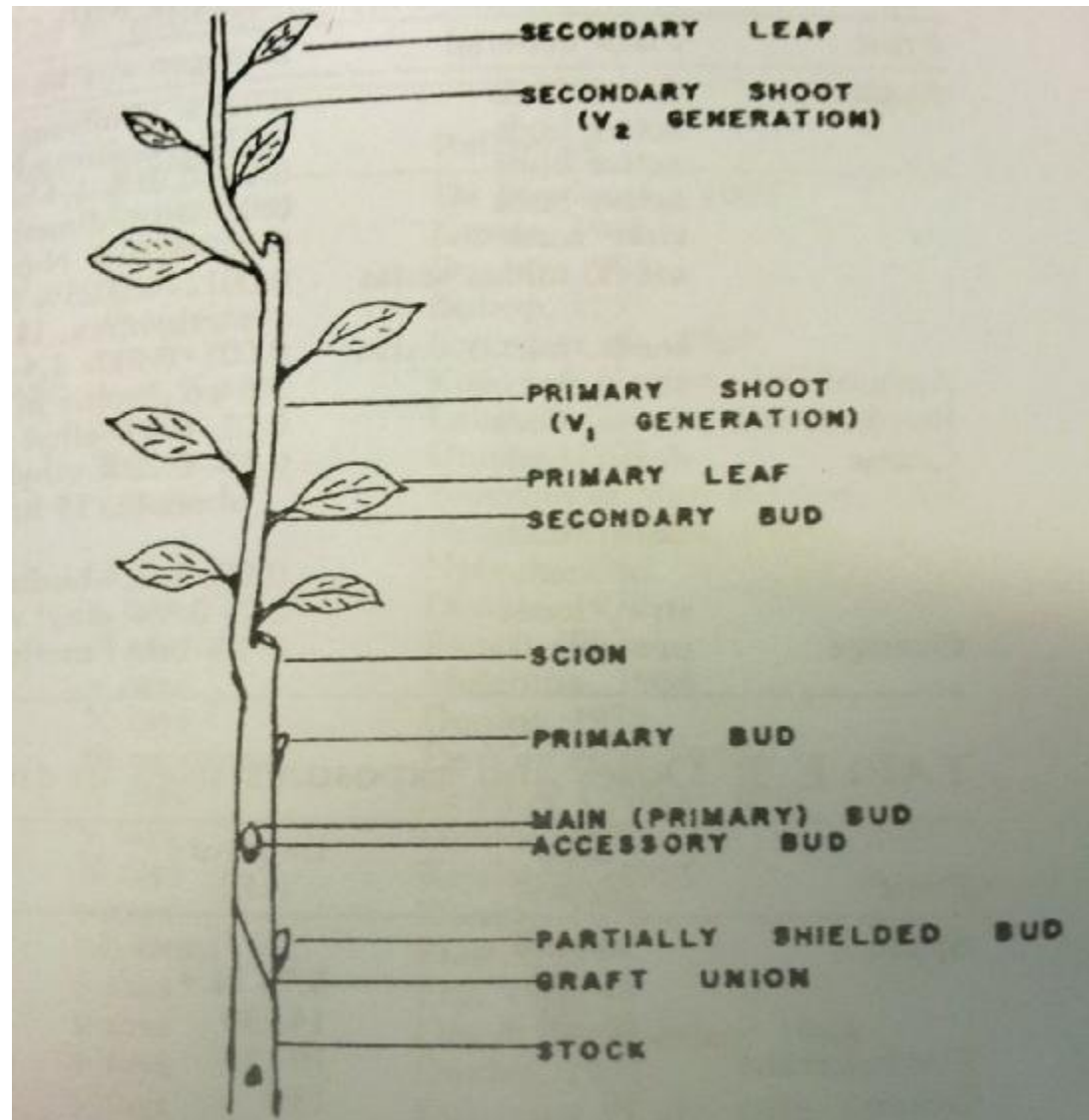
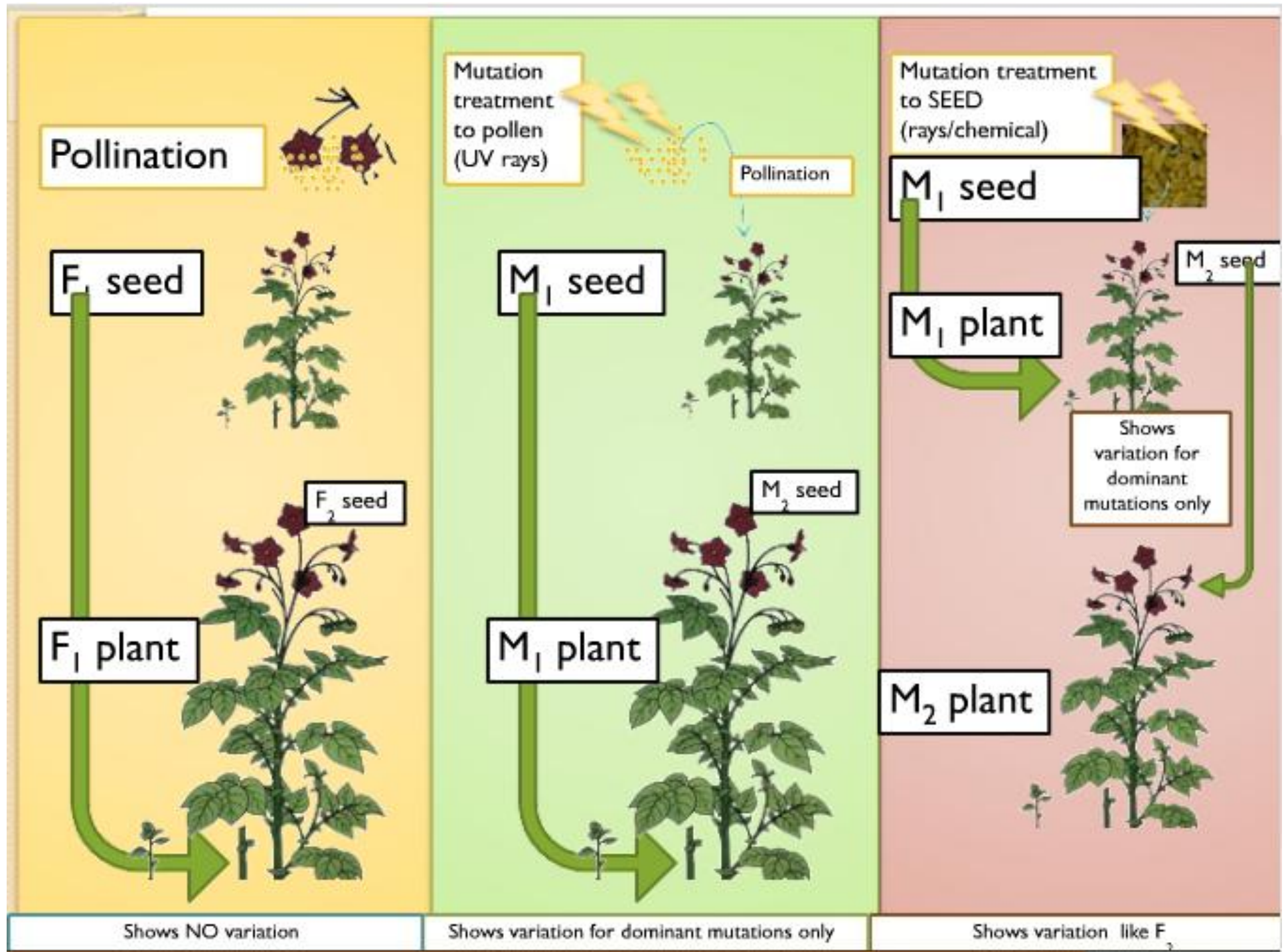

FIG. 2. Schematic drawing of an irradiated scion with primary and secondary buds, leaves, and shoots



Handling of mutagenic population

Treatment of seeds & vegetative propagules commonly produce **chimeras**.

Shoot tip meristem has three layers :-

- **L₁** :- Give rise to epidermis.
- **L₂** :- Part of leaf mesophyll & gametes.
- **L₃** :- Yield the rest of plant.

Periclinal chimera :- When the whole of **L₁**, **L₂** or **L₃** layer is affected.

Sectorial chimera :- When only a part of **L₁**, **L₂** or **L₃** layer is affected .



In sexually reproducing species L_2 chimera will be transmitted to the next generation.

In sexually reproducing crops mutation breeding utilize both recessive & dominant mutations.

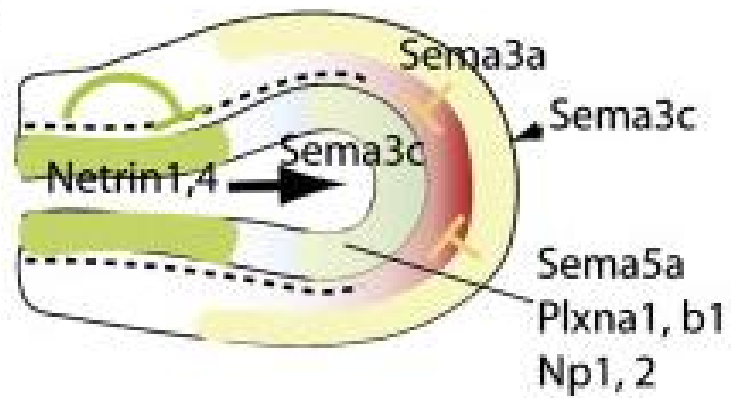
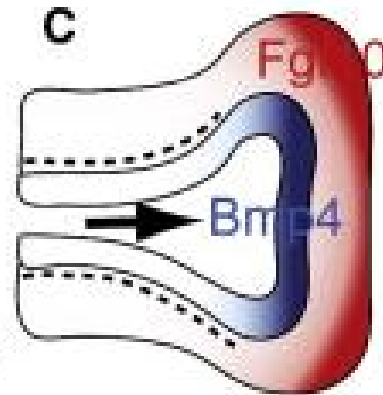
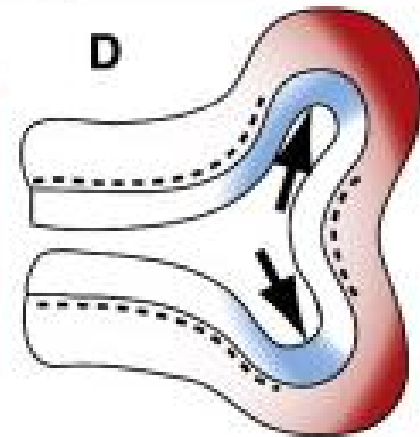
A**B****C****D**

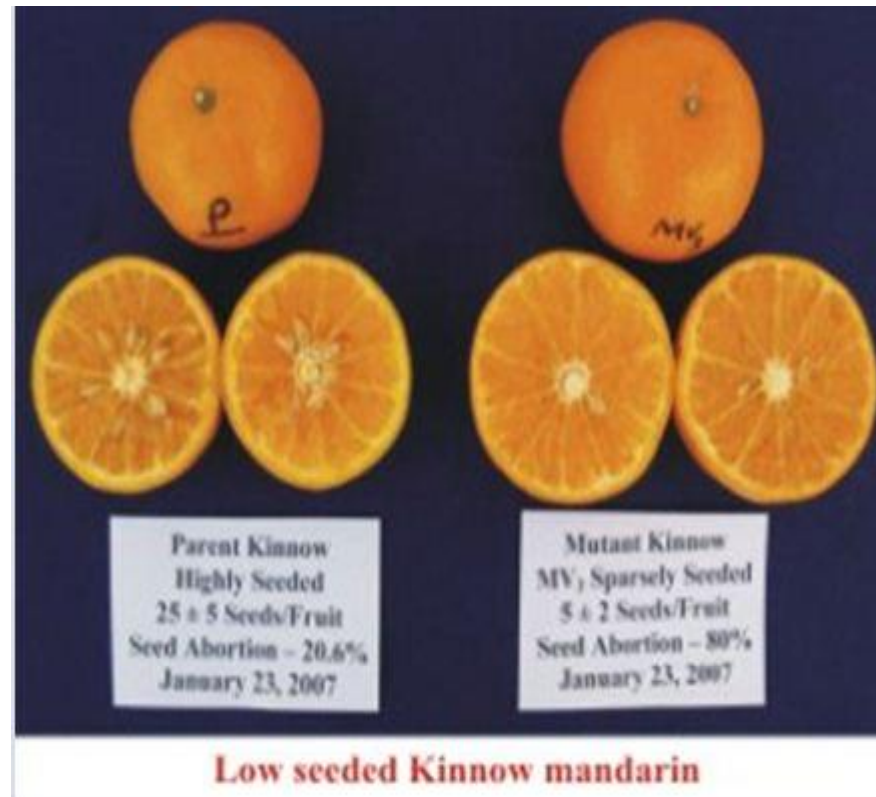

- Seedless Kinnow is the demand of local juice industry and the foreign markets. A sparse seeded (5 ± 3 seeds/fruit) mutant Kinnow has been developed as a result of induced mutation with gamma irradiation of dormant bud of high seeded (25 ± 5 seeds/fruit) parent Kinnow. The conventional scion/stock graft techniques were used for the propagation of mutant. The material has been taken upto mV_5 stage of vegetative propagations, with the confirmation of continuity of the induced character. The rootstocks of *Citrus jambhiri* are being grafted from scions of mV_5 and provided to farmers for general cultivation.



- The Rio Star® Grapefruit, a product of radiation-induced mutations, now accounts for three quarters of all grapefruit trees grown in Texas. The mutant strain was developed by Richard A. Hensz, a Texas horticulturalist and director of the Texas A&I University Citrus Center in Weslaco, Texas. Working at the Brookhaven National Laboratory in Long Island, Hensz began irradiating seeds from the famous Ruby Red grapefruit using X-rays in 1963. In 1976, he produced a new strain that was resistant to cold temperatures. Grapefruit crops had been devastated by severe freezes in the past; when another hit in December of 1983, the Rio Star® trees were spared. The Citrus Center began giving away Rio Star® seeds to farmers in 1984. The sweet, dark-red fruit quickly became popular among growers and consumers.

Gamma Field at the Institute of Radiation Breeding in Japan



- The gamma field encompassed 12.8 acres of land that Brookhaven scientists used to experiment on more than 300 plant species. In 1959, the researchers observed that radiation from the gamma field had injured nearby trees. The finding prompted them to create a 'gamma forest,' which examined the effects of gamma rays on an entire ecosystem. The gamma greenhouse was a concrete structure with a lead cap surrounded by earthen embankments. Cobalt-60 was raised from a shielded receptacle in the floor. The 'hot cell' was a small (2 meter) shielded chamber. A radiation source was lowered from the ceiling. Plants were placed on removable shelves that could be accessed through a set of sliding doors coated with lead. In the gamma pool, radioactive materials were lowered into the water to shower plant specimens placed at the bottom.

polyploidy

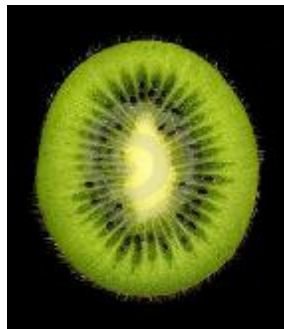

Polyploidy = the addition of one or more complete sets of chromosomes to the original set.

two copies of each autosome = diploid

four copies of each autosome = tetraploid

six copies of each autosome = hexaploid

Organisms with an odd number of autosomes, e.g., the domestic banana plant (*Musa acuminata*), cannot undergo meiosis or reproduce sexually.



Musa barbisiana (diploid)



Musa acuminata (triploid)

Monoploidy

...a haploid of a diploid is monoploid,

...has one chromosome set.

The gametes of diploids are haploid, those of tetraploids are diploid, those of hexaploid are triploid, and so on.

Monoploid Applications

- monoploid plants can be created by culturing pollen grains ($n = 1$),
 - the population of haploid organisms is then screened for favorable traits,
 - the plants are then treated with colchicine which generates a $2n$ plant homozygous for the favorable traits.

Two main types of polyploidy:
autopolyploidy (genome doubling) = the multiplication of one basic set of chromosomes
allopolyploidy = the combination of genetically distinct, but similar chromosome sets.

Autopolyploids are derived from within a single species; allopolyploids arise via hybridization between two species.

Autopolyploidy

...polyploidy resulting from the replication of one or more sets of chromosomes,

...the additional set of chromosomes is identical to the normal haploid complement of that species.

autopolyploidy

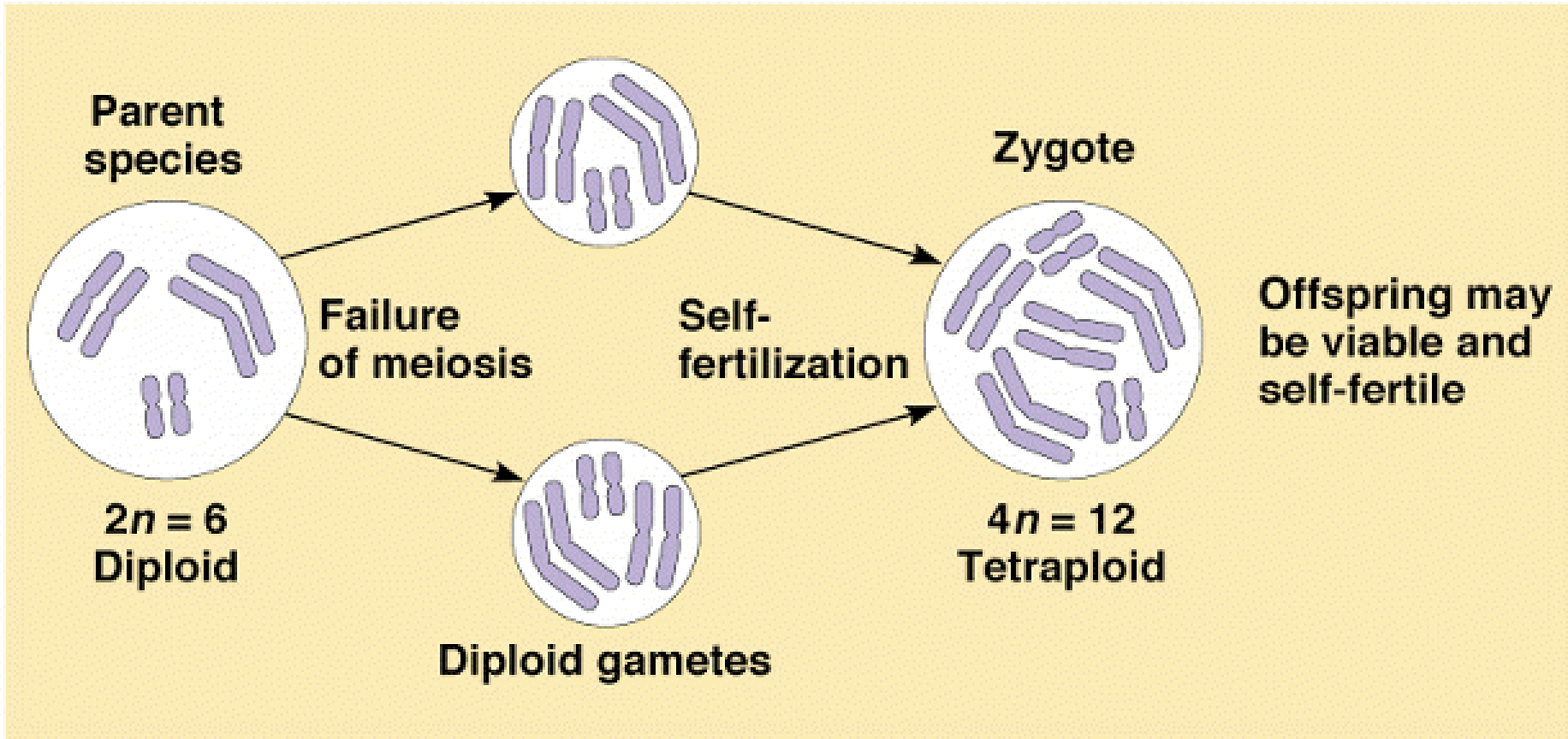

Autopolyploidy

...can be induced by treating cells with the drug colchicine,

colchicine: is a alkaloid derivative from the autumn crocus (*Crocus veneris*),

...inhibits microtubule polymerization, and thus inhibits the separation of chromosomes during meiosis.

Autopolyploidy Applications

- Treating a plant with colchicine often produces autopolyploidy, resulting in plants with larger flowers and/or fruit,

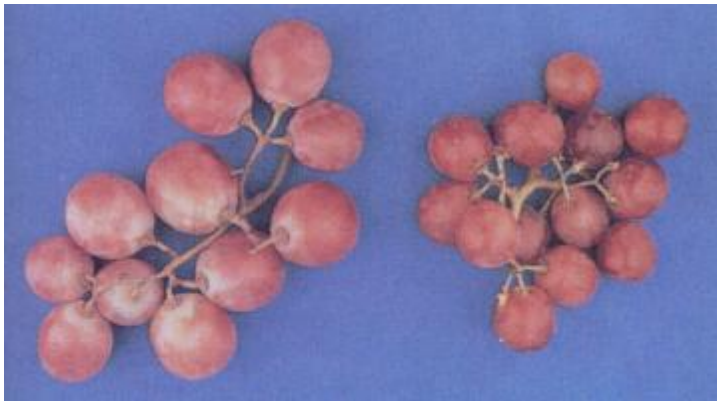

$4n$

$2n$

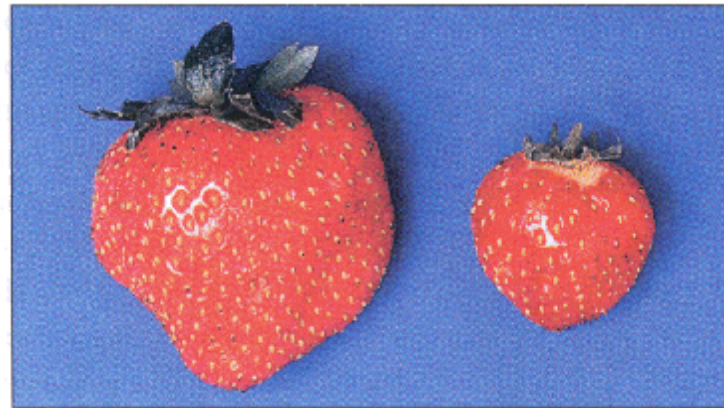

$8n$

$2n$

allopolyploidy

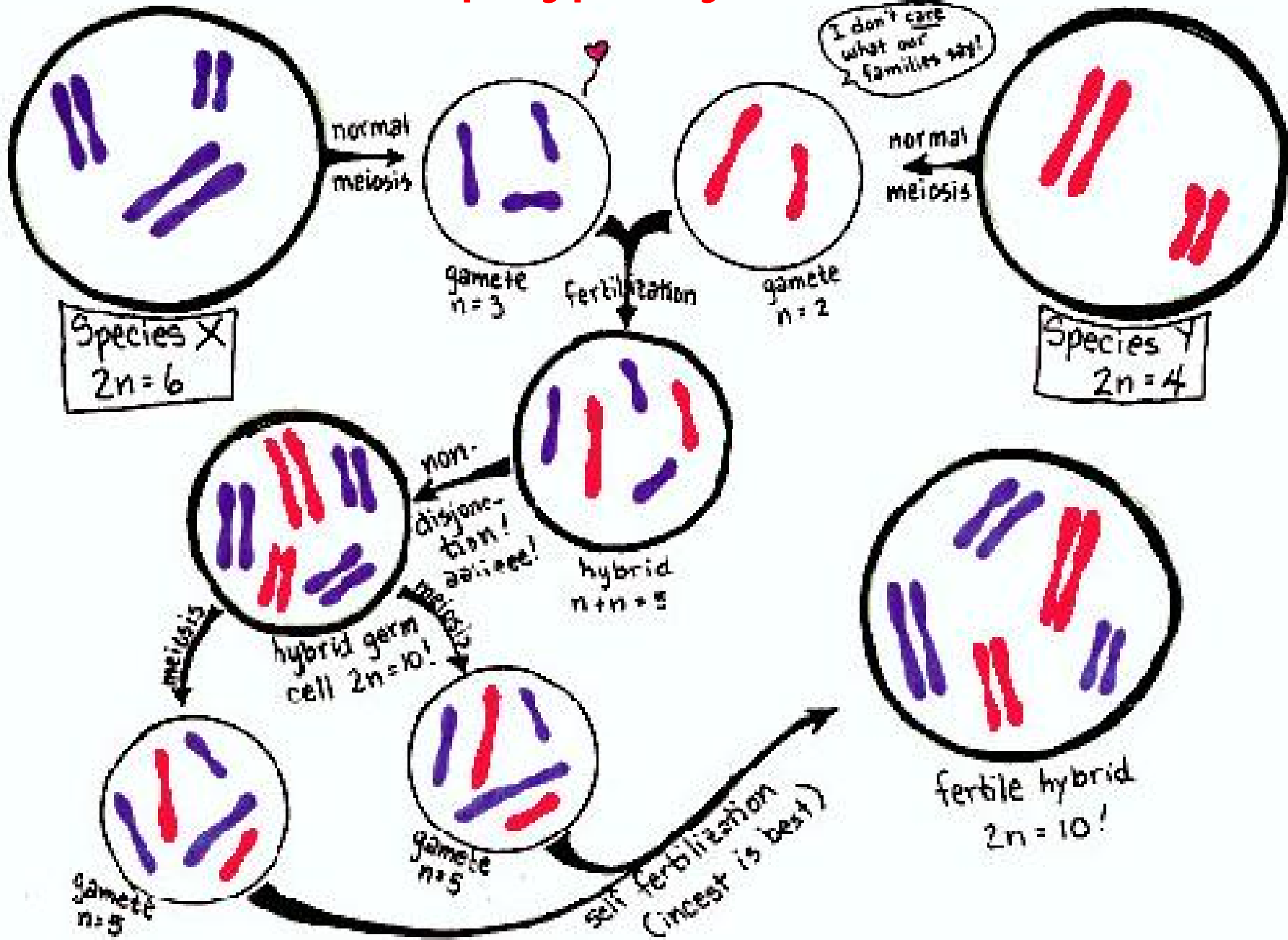

Allopolyploidy Applications

B. oleracea (cabbage, cauliflower, Broccoli, kale, etc.)

$$2n = 18$$

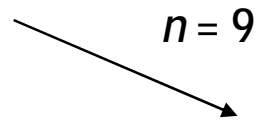

B. napas (Oil rape, canola oil)

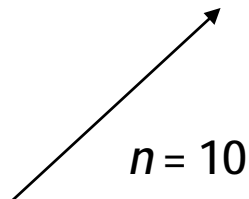

B. campestris (turnip, turnip rape)

$$2n = 20$$

$$4n \times 2n = 3n?$$

- The creation of triploids can be accomplished by crossing a tetraploid with a diploid,
- Most triploid individuals are sterile.

Triticum urartu (AA) × *Aegilops speltoides* (BB)



T. turgidum (AABB) × *T. tauschii* (DD)



T. aestivum (AABBDD)



The common bread wheat (*Triticum aestivum*) is an allohexaploid containing three distinct sets of chromosomes derived from three different diploid species of goat-grass (*Aegilops*) through a tetraploid intermediary (durum wheat).

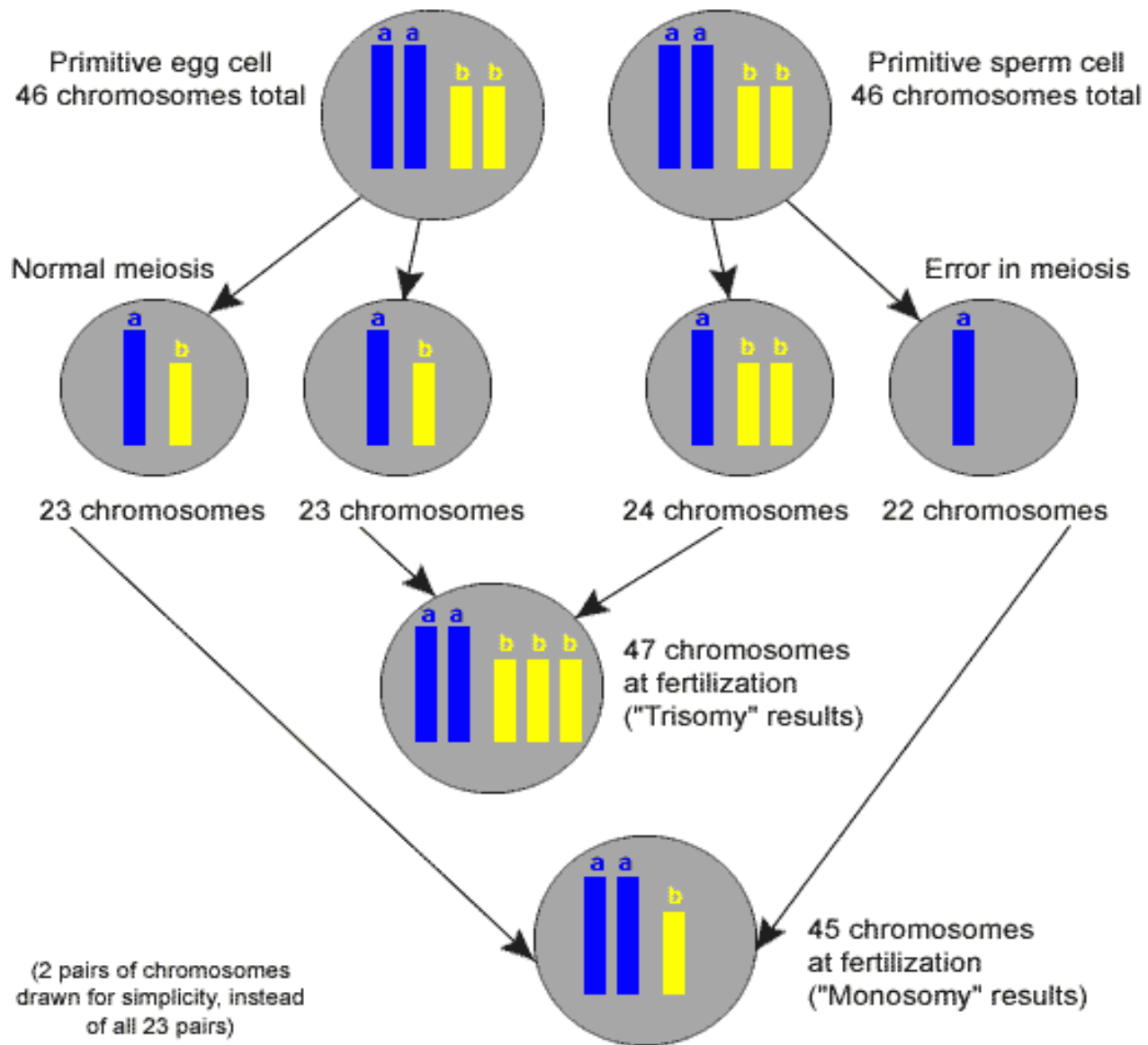

Meiosis

Parent cell



DNA replicates



2 daughter cells



4 daughter cells

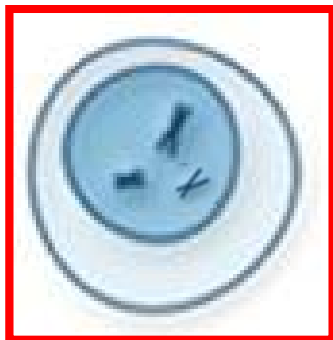

haploid (1N)

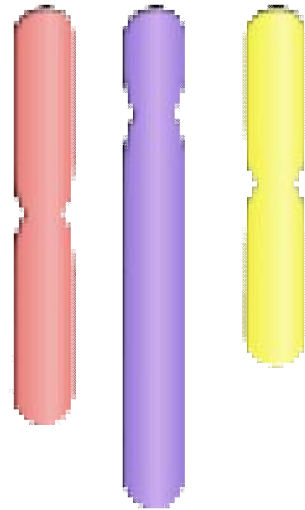

Diploid (2N)

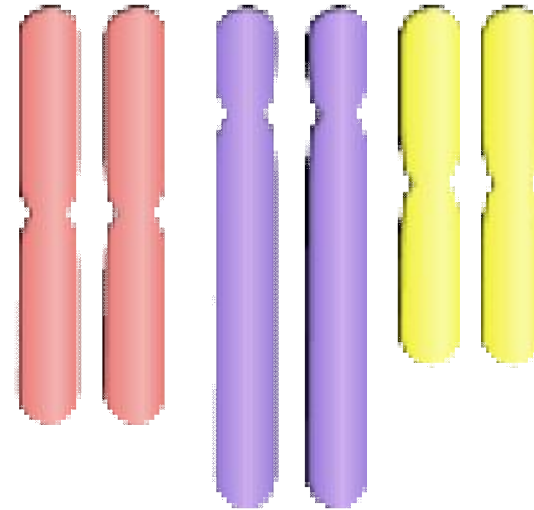

triploid (3N)

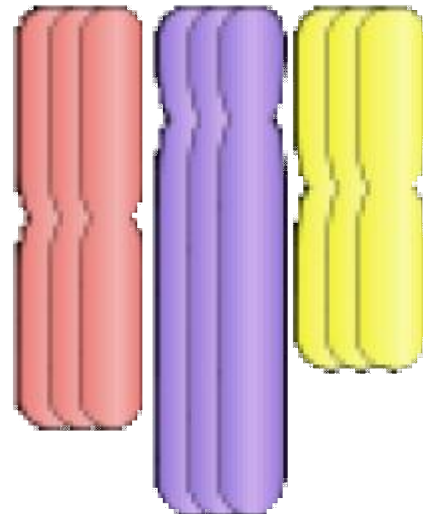

tetraploid (4N)

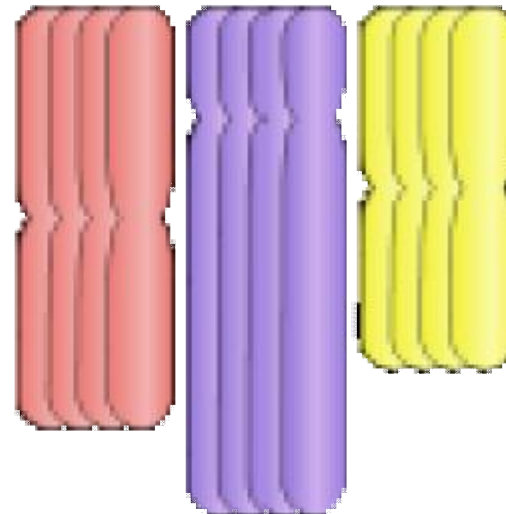

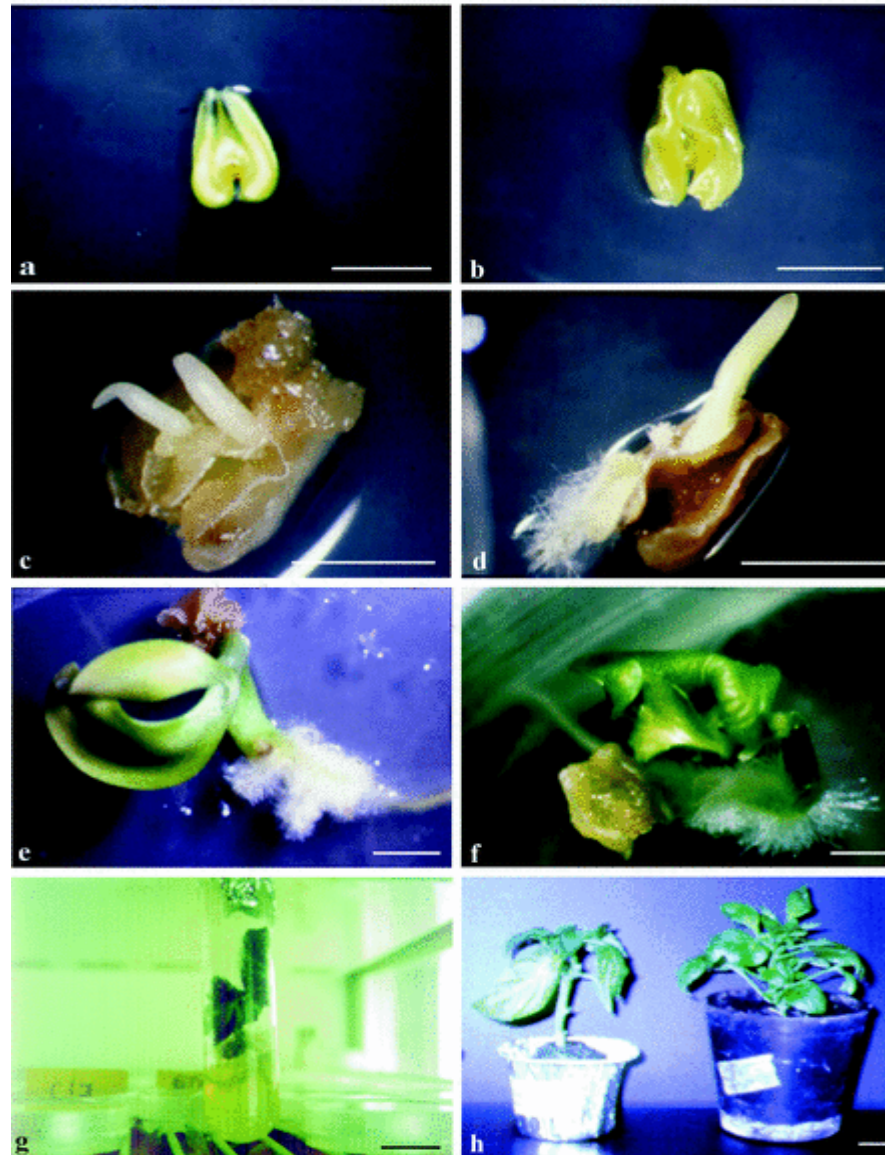

- After 6 days in culture, responsive anthers swelled and increased in size up to 1.5 ± 0.2 -fold (Figure 1b). Many other anthers became dark and lost turgescence. Later, 20 to 30 days, white elongated structures emerged from the responsive anthers (Figure 1c). These were identified as embryos, showing roots and shoots at later stages (Figure 1d). These embryos proceeded through the cotyledonal stage (Figure 1e), and finally towards green plantlets with leaves (Figures 1f and 1g). After 80 days, the regenerated plants developed a normal anatomy, but, in some cases, they were smaller with less leaves (Figure 1h, left-hand side) and grew less vigorously than control diploid plants (Figure 1h, right-hand side).

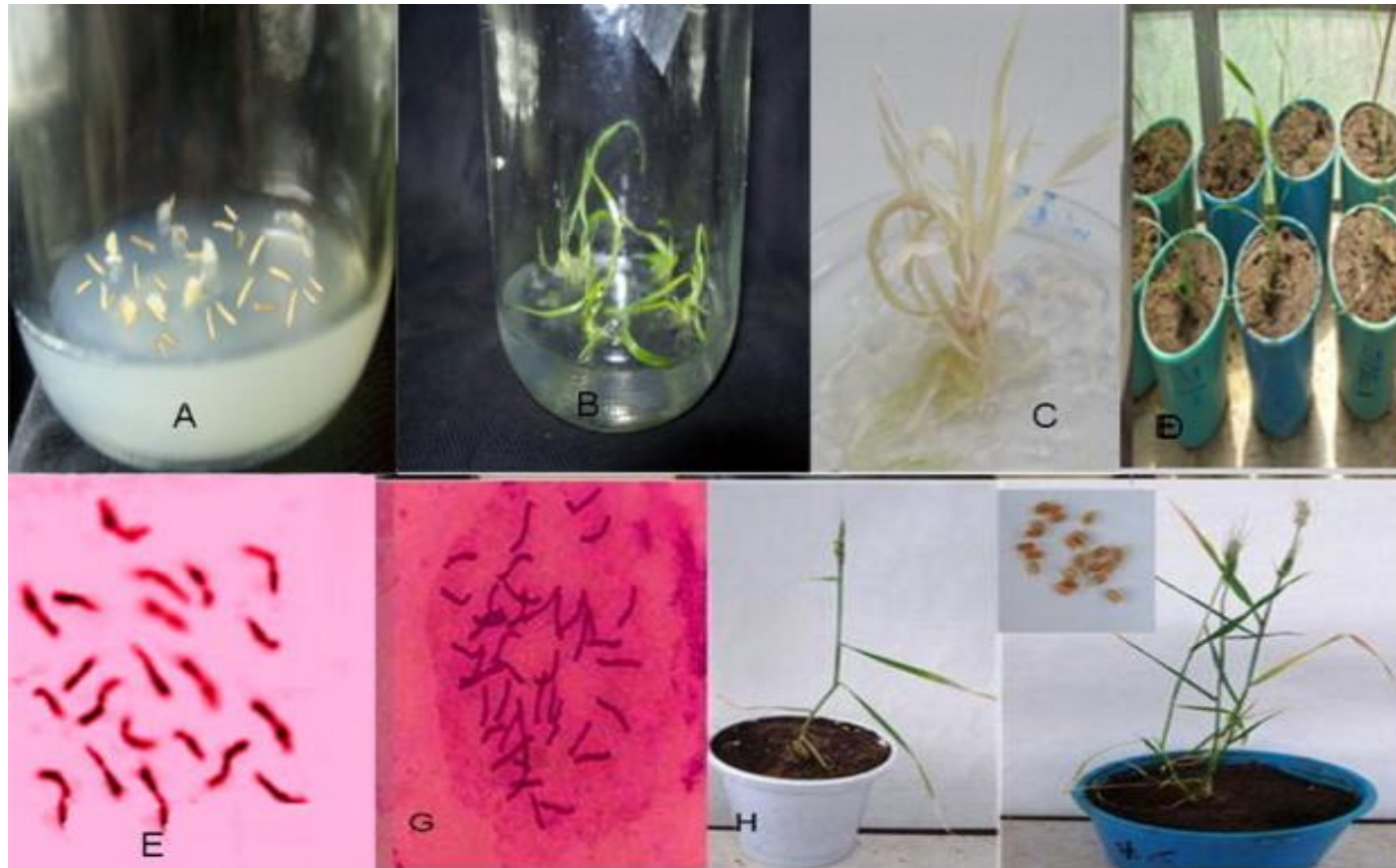

- In vitro induction of haploid wheat plants through anther culture and their subsequent transfer to pots. (A) Formation of callus in the cultured anthers. (B and C) Green and albino plantlets emerging from cultured anthers. (D) Plantlets in greenhouse. (E) Haploid chromosome number ($n = 3X = 21$). (G) Double haploid chromosome number ($2n = 6X = 42$). (H) Sterile plant (spike abnormal). (I) Fertile plants, normal spike and seeds obtained from the same plant.



- *a.* C.1 double haploid plant of 'Clemenules'. *b.* G haploid plant of 'Clemenules'. *c.* Detail of blossom of the G haploid plant. *d.* Haploid and diploid flower of 'Clemenules'. *e.* B.1 aneuploid plant of 'Clemenules'.

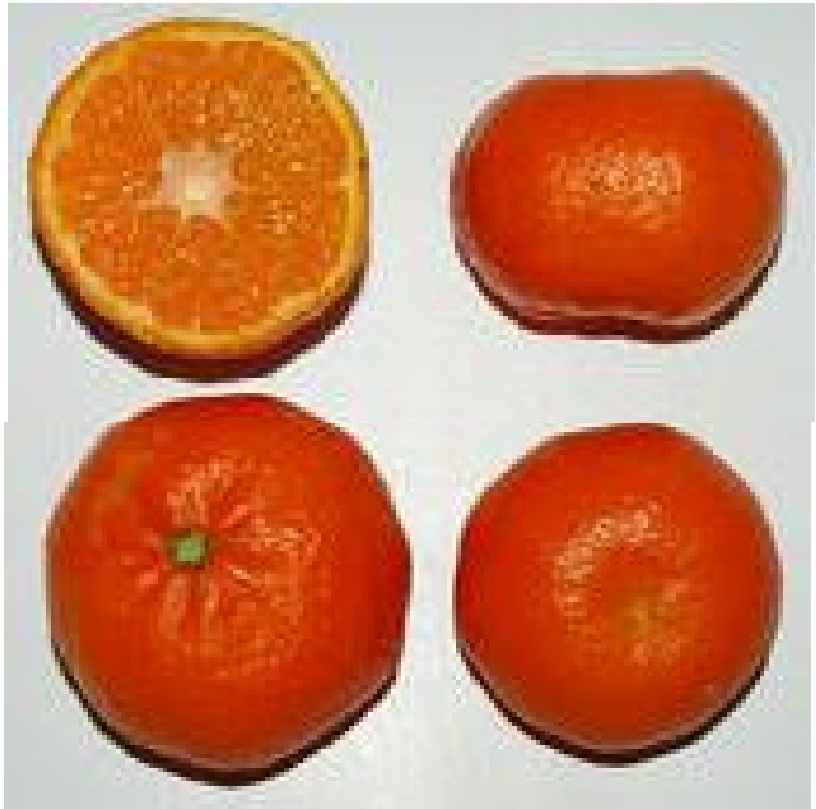
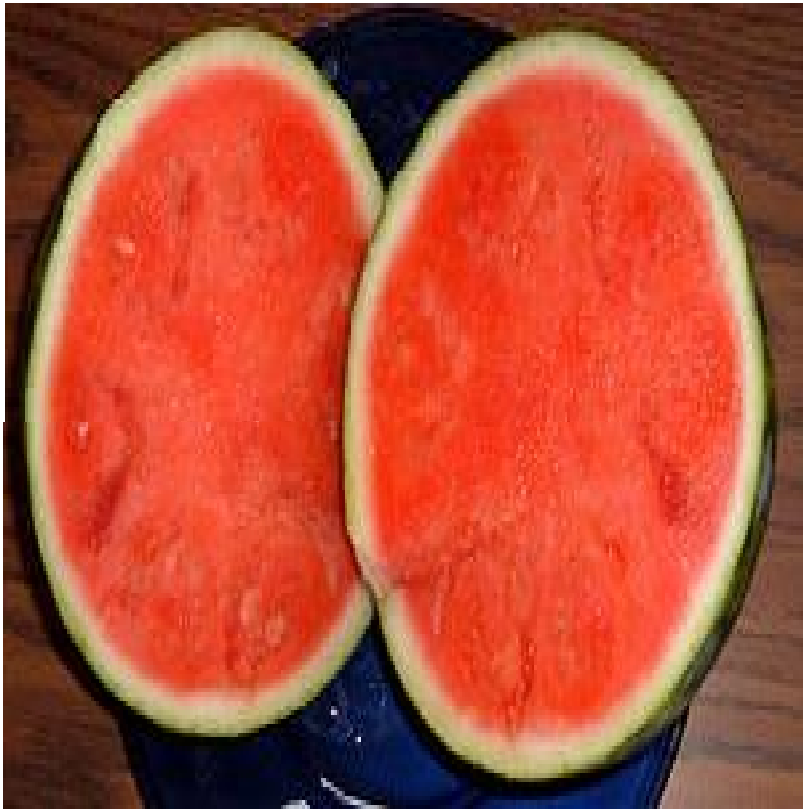

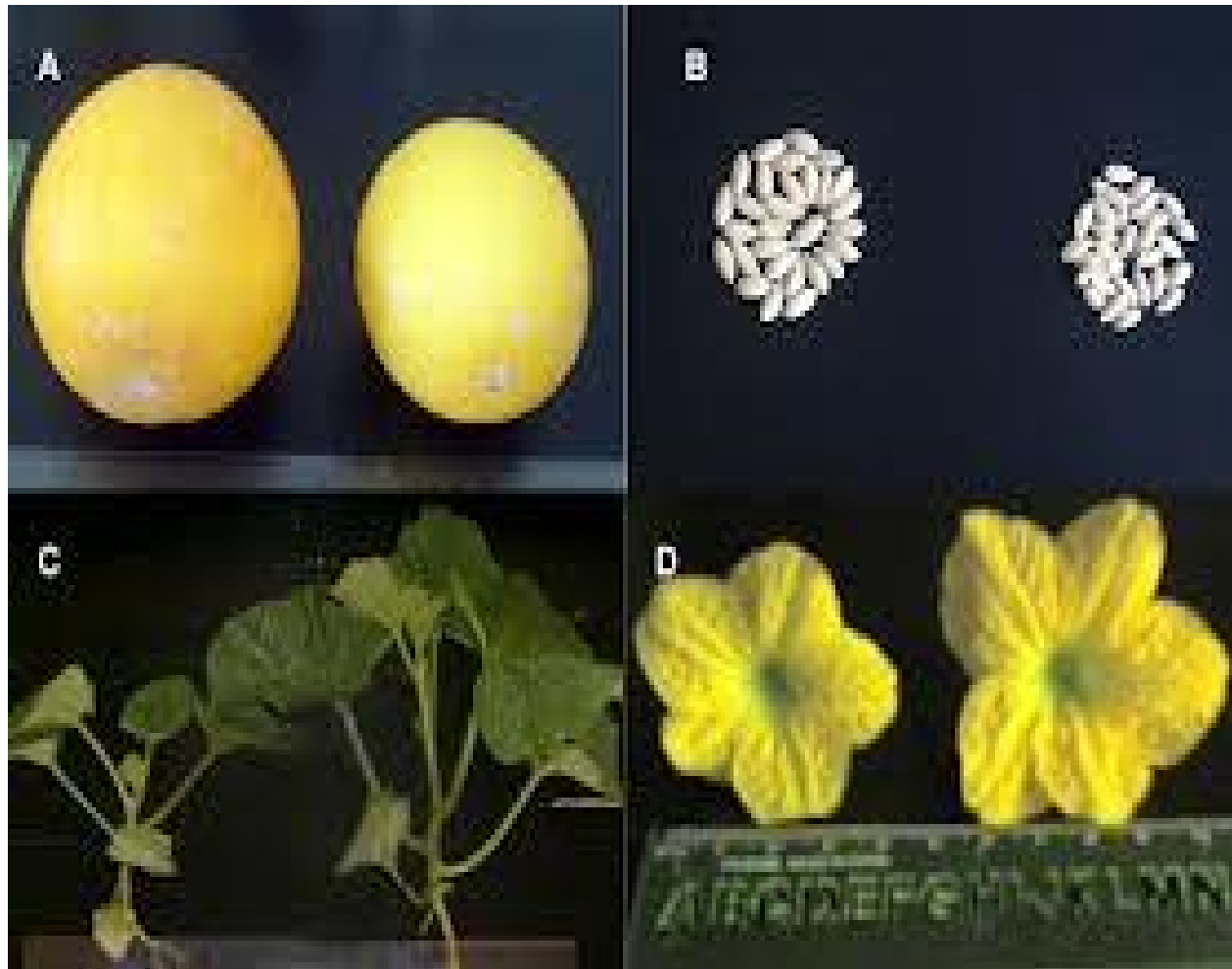

- Morphological characteristics of tetraploid and diploid muskmelon. (A) Fruit of tetraploid (left) and diploid (right), (B) seeds of tetraploid (left) and diploid (right), (C) 40-day-old plants of diploid (left) and tetraploid (right), (D) flowers of diploid (left) and tetraploid (right).

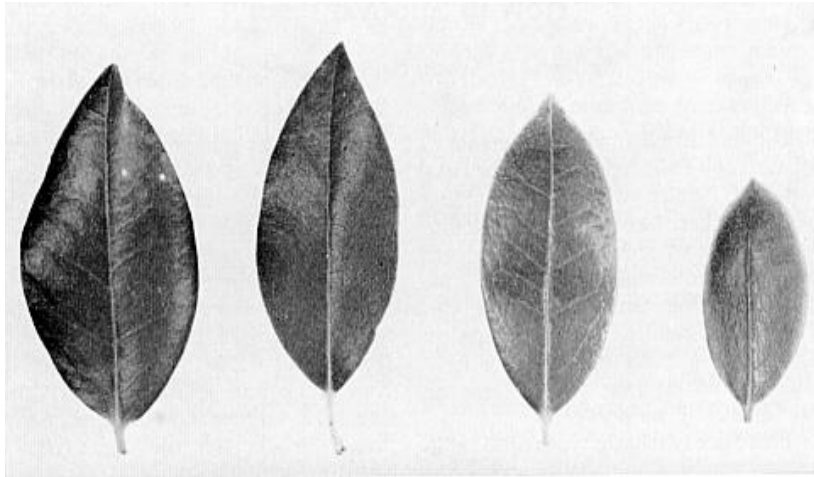
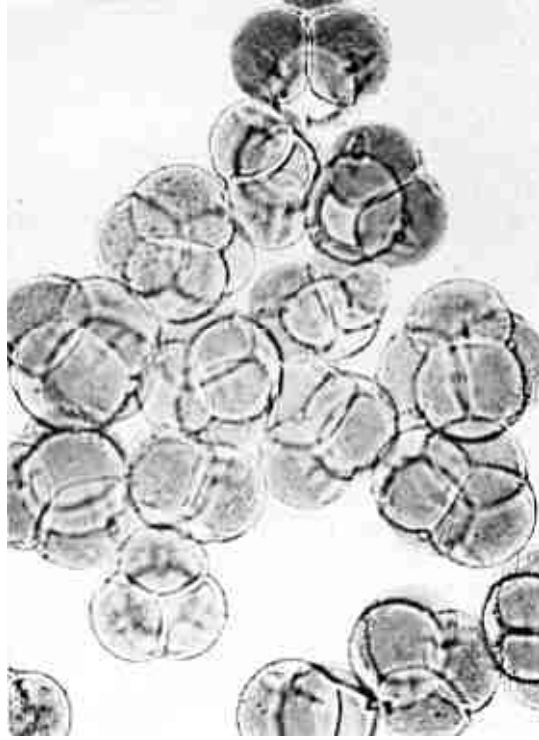
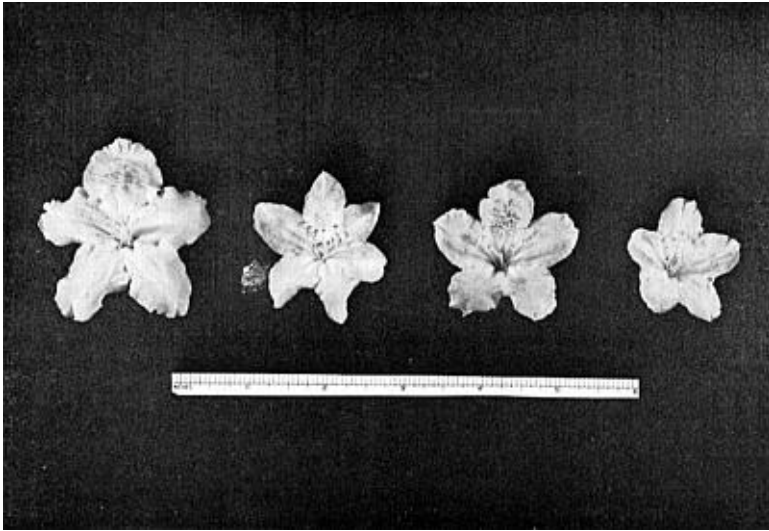

Raphanus X *Brassica* = *Raphanobrassica*
 Radish Cabbage Rabbage
 (2n = 18) (2n = 18) (2n = 18)

RRRRRRRRR
 RRRRRRRRR
 Fertile

CCCCCCCCC
 CCCCCCCCC
 Fertile

RRRRRRRRR
 CCCCCCCCC
 Sterile
 (synaptic failure)

Diploid (2n) Rabbage $\xrightarrow{\text{colchicine}}$ Tetraploid (4n) Rabbage

RRRRRRRRR
 CCCCCCCCC

RRRRRRRRR CCCCCCCCC
 RRRRRRRRR CCCCCCCCC

The Formation Of A Fertile Tetraploid Rabbage

R = radish chromosome C = cabbage chromosome





Gene Transfer

DNA Construct

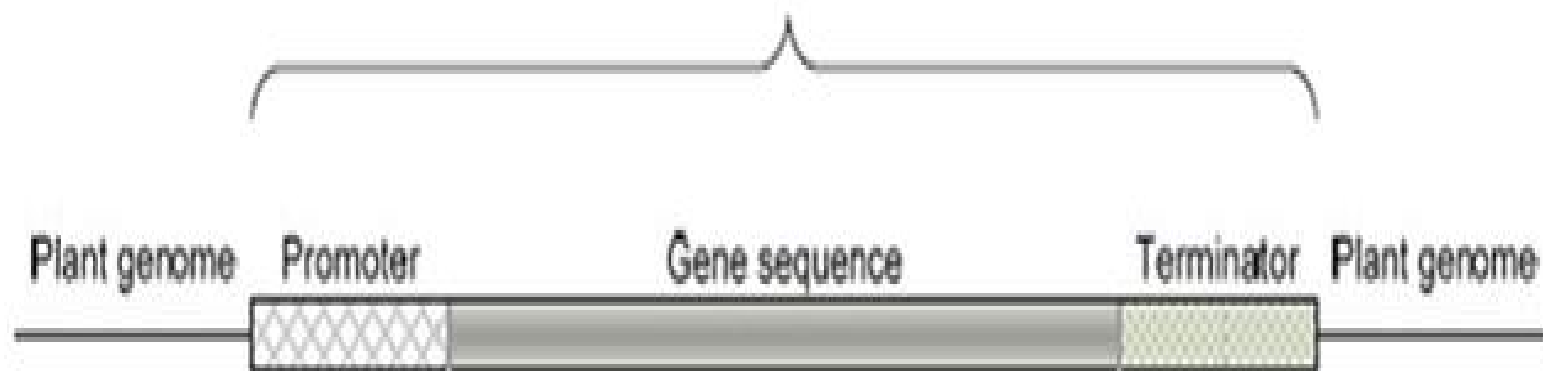

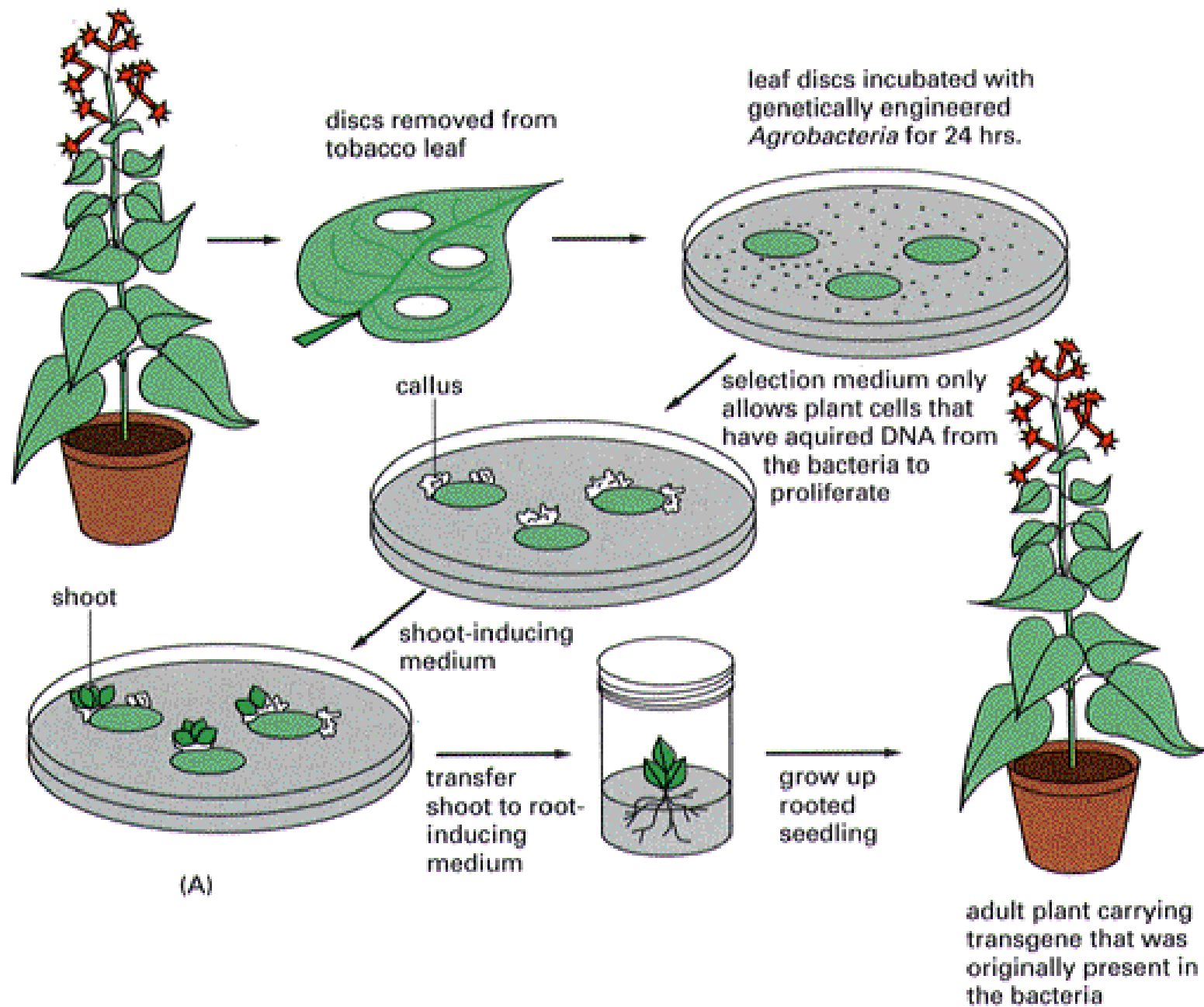

Gene Gun

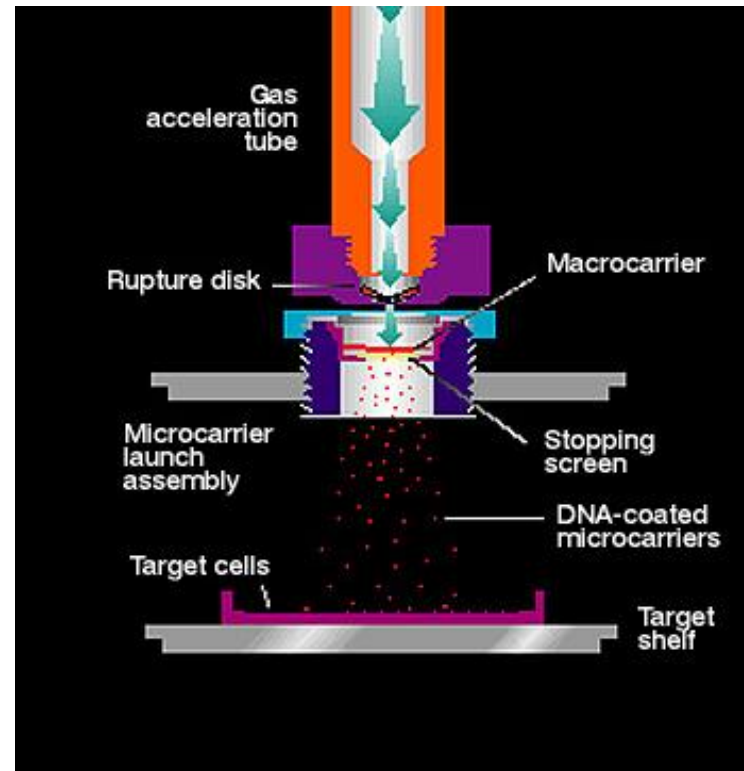



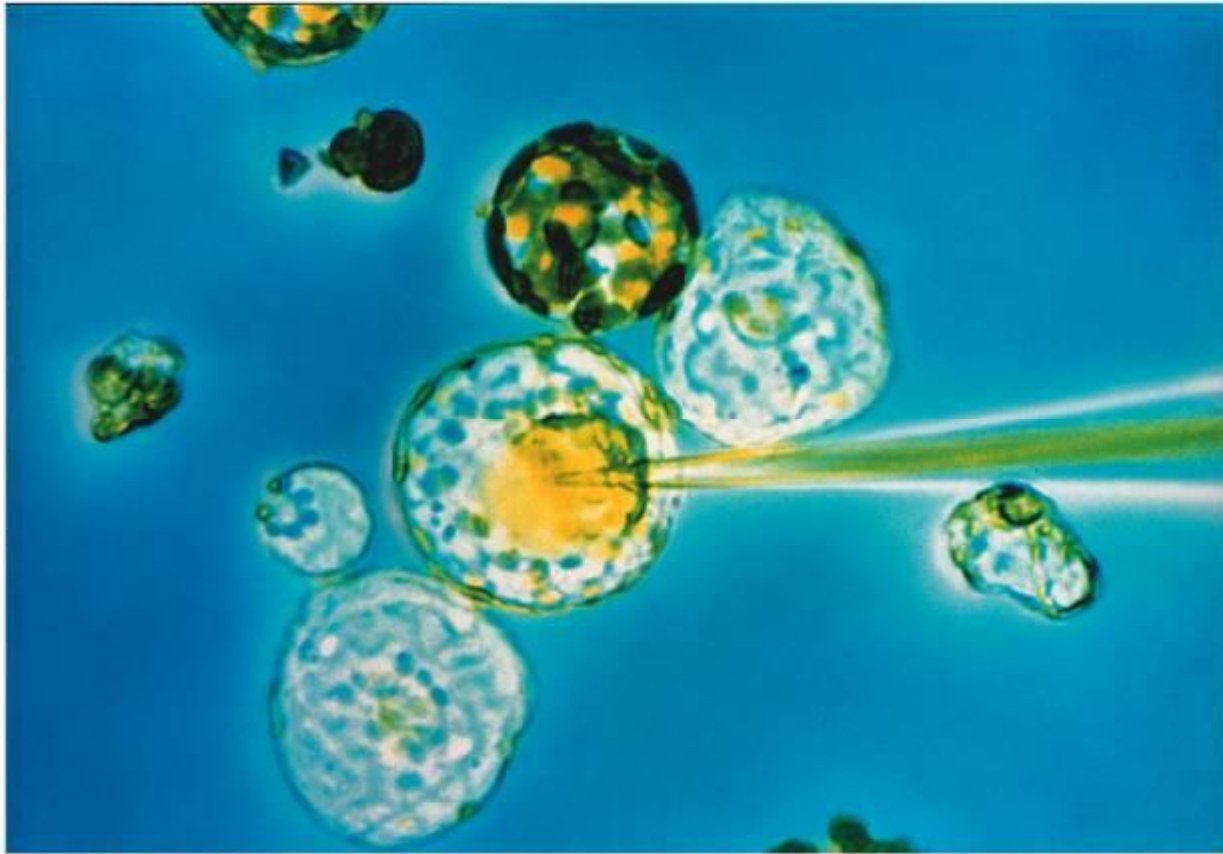

Copyright © 2004 Pearson Education, Inc., publishing as Benjamin Cummings.

PARTICLE GUN METHOD

partides coated with DNA including the desired gene and an antibiotic resistance gene

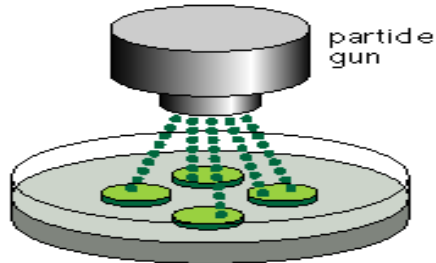

bombardment of plant pieces with partides

AGROBACTERIUM METHOD

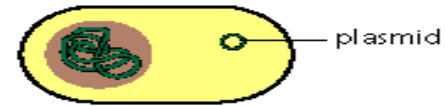

Agrobacterium with circular plasmid carrying the desired gene and an antibiotic resistance gene

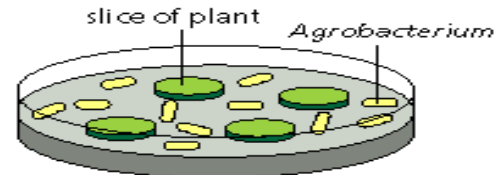

growth of *Agrobacterium* with plant pieces

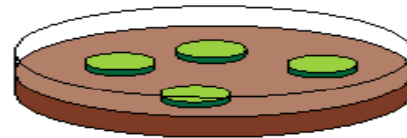

incubation in growth medium with antibiotic

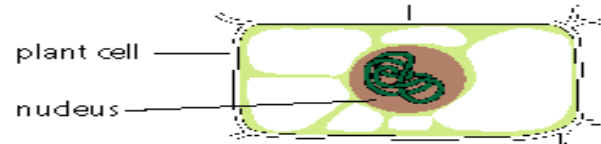

growth of plant cells whose chromosomes have integrated an antibiotic resistance gene and desired gene

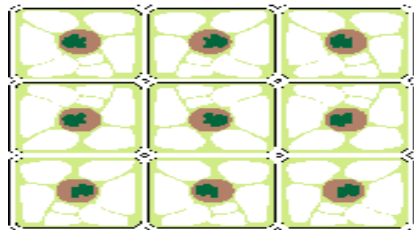

cell multiplication



shoot regeneration followed by root regeneration



plant with new trait

Process

1. Restriction enzymes cut out gene that is to be transferred
2. The same restriction enzyme cuts into the plasmid
3. Because it is the same restriction enzyme, the same complementary 'sticky ends' in the plasmid

Process

4. DNA ligase joins the sticky ends, fixing the gene into the E.coli plasmid
5. The recombinant plasmid is inserted into the host cell.
6. It now expresses the new gene.

Transformation: Absorption of Free DNA

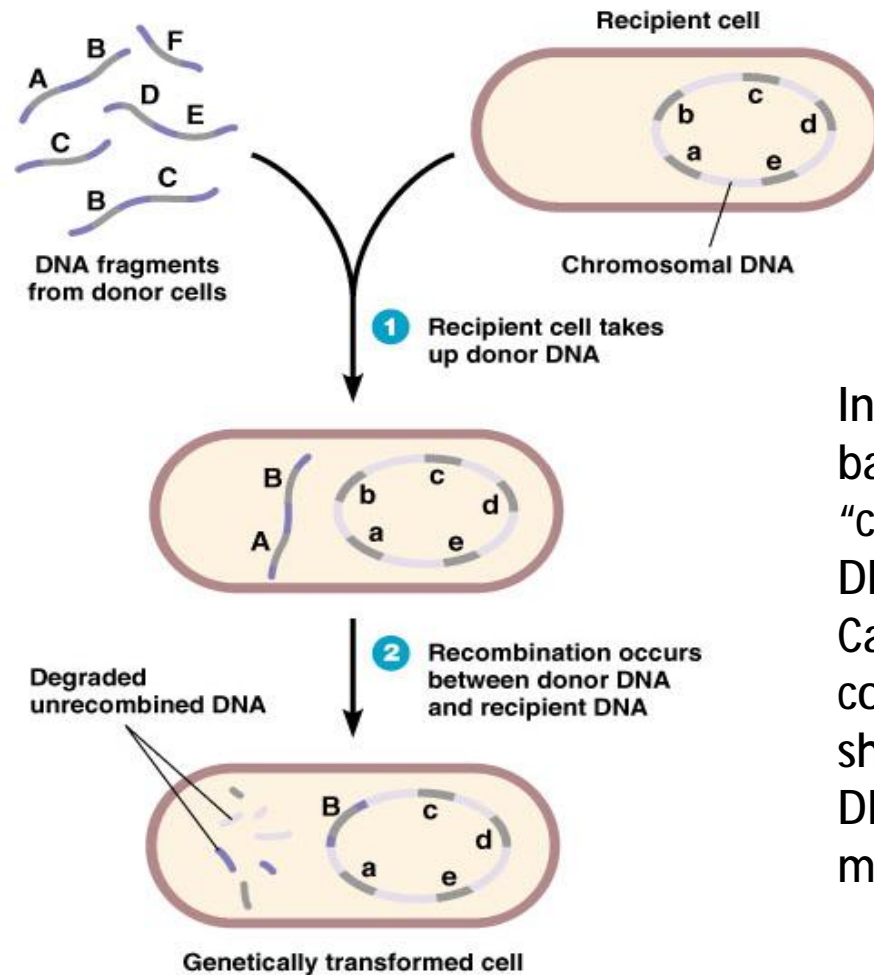

Copyright © 2004 Pearson Education, Inc., publishing as Benjamin Cummings.

In a lab setting, many bacterial species are not “competent” to take up donor DNA. They are incubated in CaCl_2 to make them competent and then heat shocked so they will suck up DNA fragments from the medium.

Figure 8.24

Recombination Produces New Genotypes

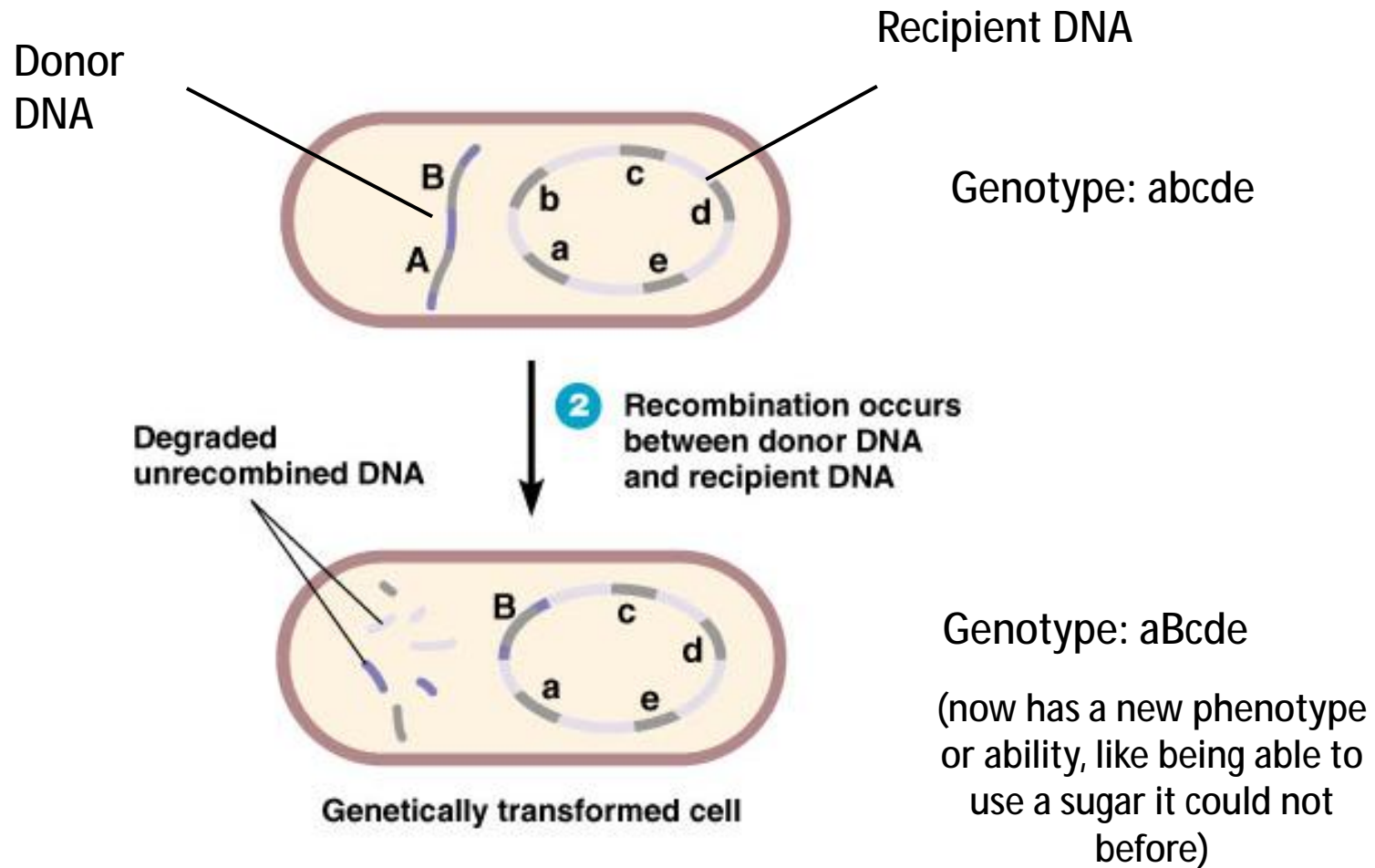
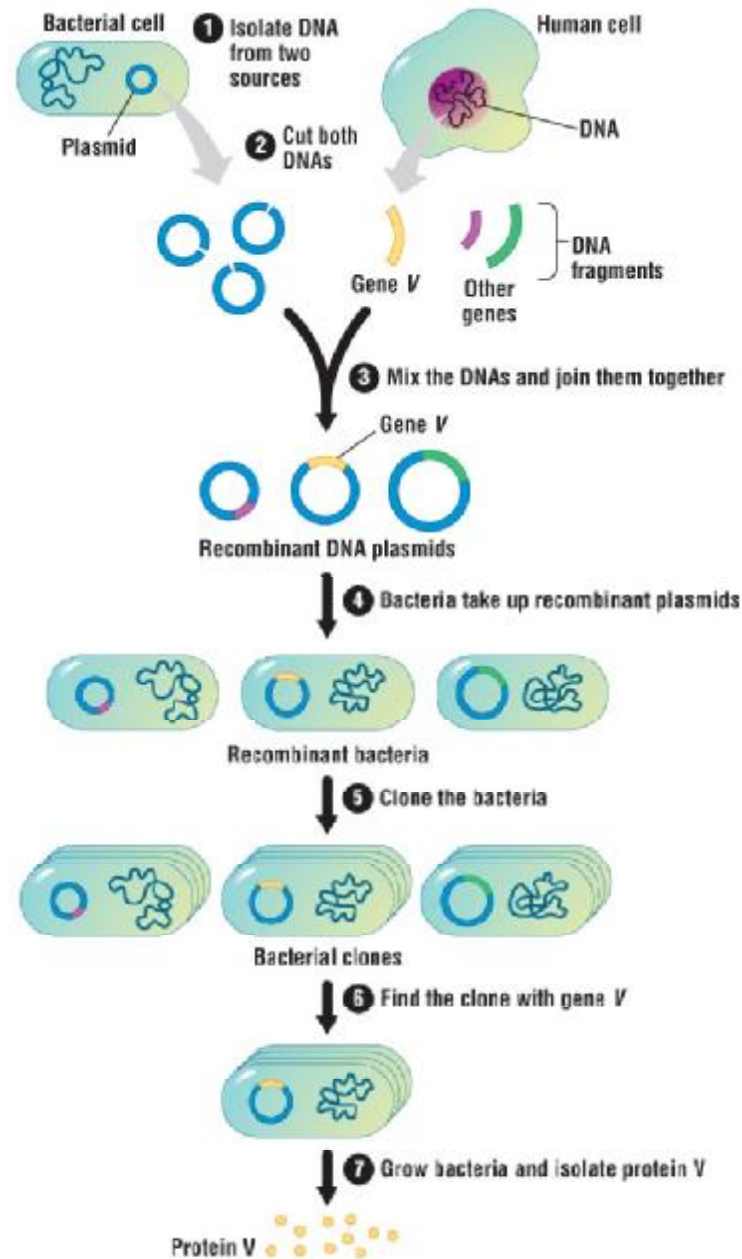
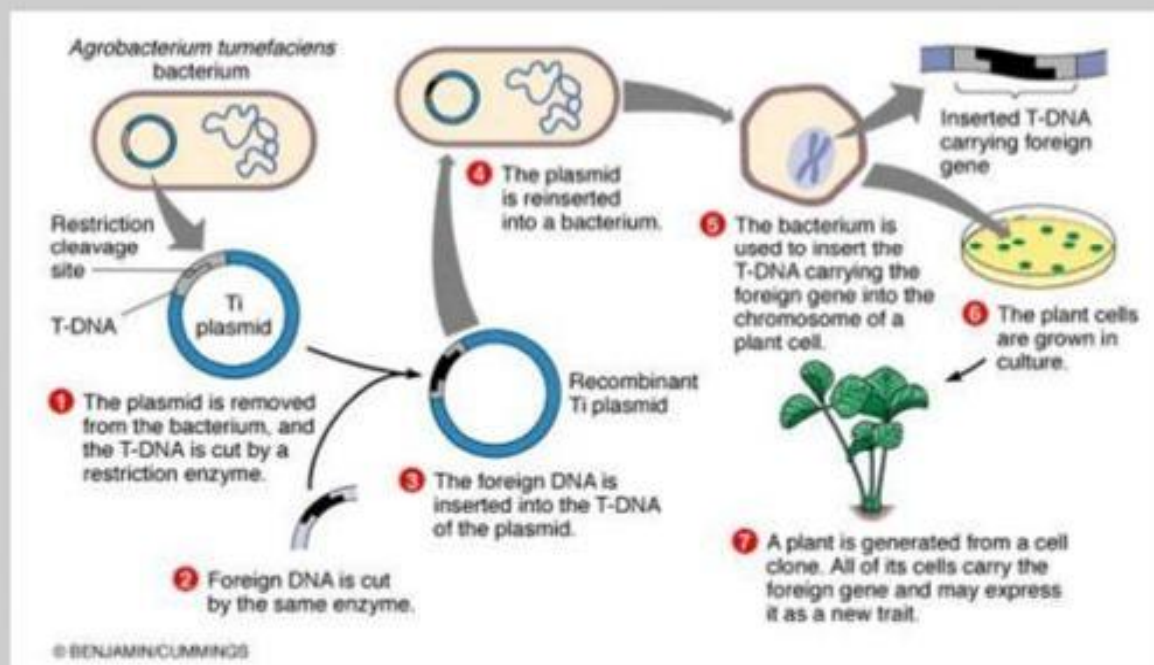

Figure 8.25

Genetic Engineering Involves Insertion of a Gene on a Plasmid



An example



Polymerase Chain Reaction: DNA Replication in a Test Tube

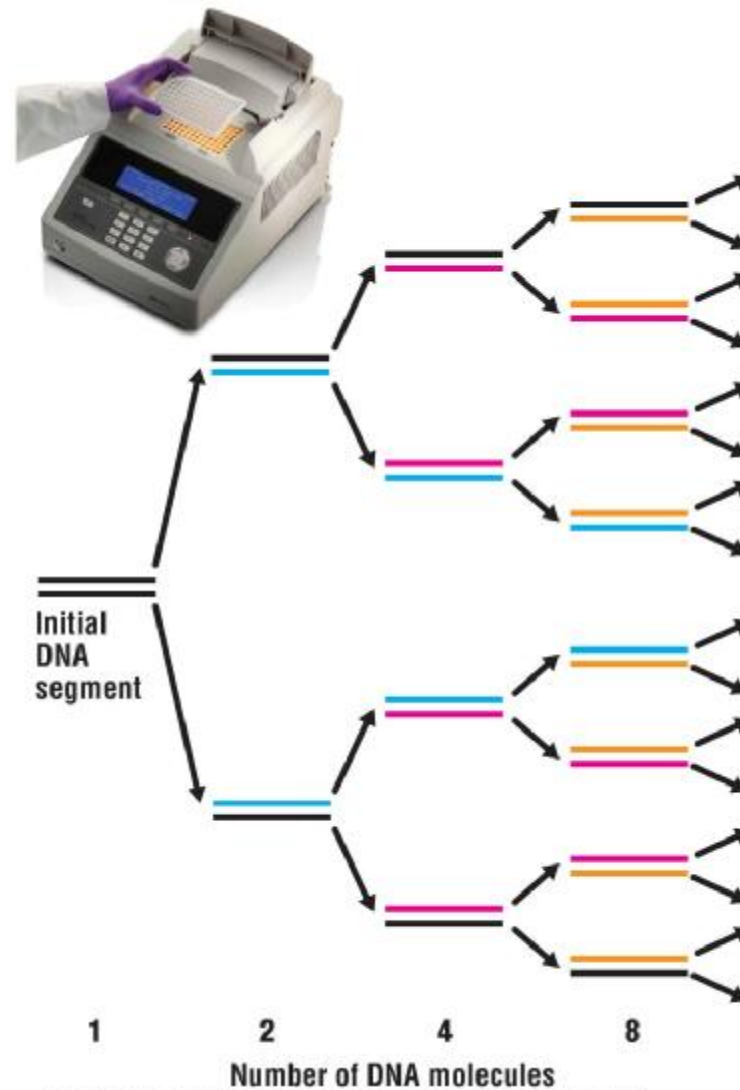

Copyright © 2007 Pearson Education Inc., publishing as Pearson Benjamin Cummings. All rights reserved.

Exponential Increase in the Number of DNA Molecules each Cycle

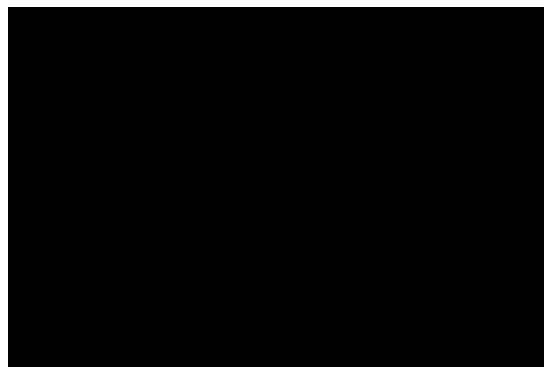
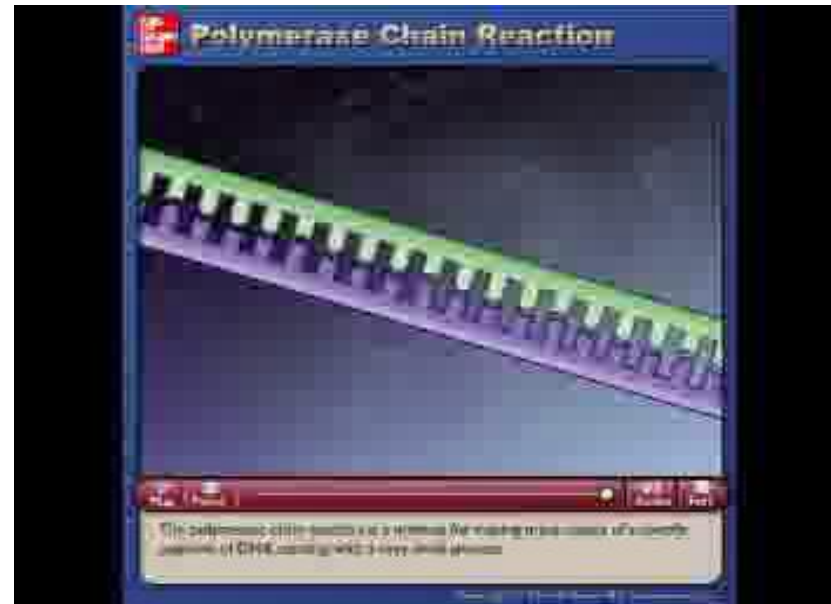
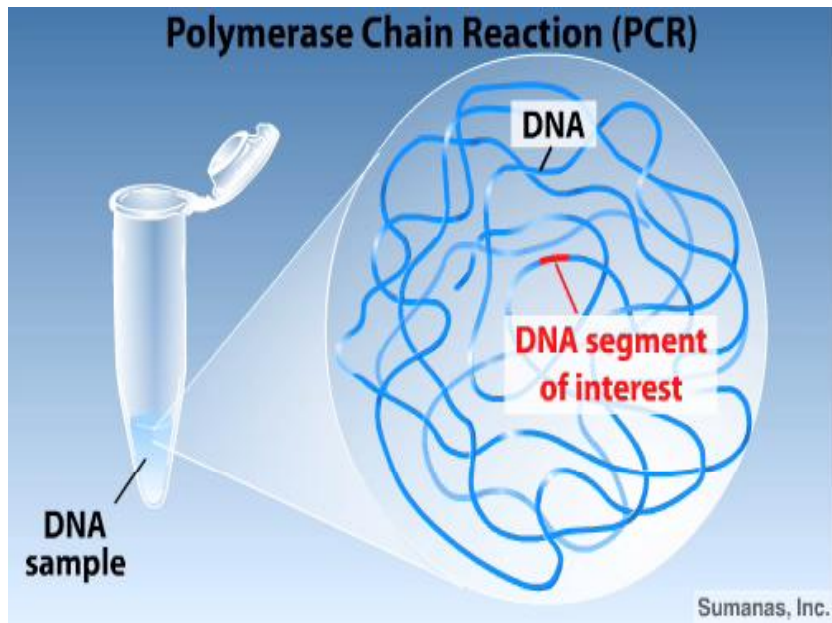

M 1 2 3 4 5 6 7 8 9 10 11 12 13 14 15 16

